

A 5G AMERICAS
WHITE PAPER



3GPP RELEASES

16 & 17 & BEYOND

5G
americas

JAN 2021

Contents

- 1. Introduction 5
- 2. Background 8
 - 2.1 Global Market Trends 8
 - 2.2 Extension to New Use Cases 10
 - 2.3 3GPP TimeLine 11
 - 2.4 ITU-R and the 3GPP IMT-2020 Submission 11
- 3. Radio-Access Technologies 14
 - 3.1 LTE 14
 - 3.1.1 Background 14
 - 3.1.2 LTE Evolution in Release 16 14
 - 3.1.3 Further LTE Evolution in Release 17 20
 - 3.2 New Radio (NR) 20
 - 3.2.1 NR - Background 20
 - 3.2.2 NR Evolution in Release 16 21
 - 3.2.3 Further Evolution in Release 17 39
- 4. System Architecture and Network-Related Features 48
 - 4.1 5G Deployment Options and Migration 48
 - 4.2 5G RAN/CN Architecture and Key Features 52
 - 4.2.1 5G RAN and CN Architecture and Key Features for Release 16 52
 - 4.2.2 5G CN Architecture and Key Features for Release 17 59

5. Visions/Considerations on “Next Generation Wireless”	65
5.1 Use cases and corresponding capabilities	65
5.2 Some key technology components.	66
Conclusion	69
Appendix	71
Acronyms	71
References.....	77
Additional References.....	79
Acknowledgments	81

A microscopic view of a honeycomb structure, showing a dense array of interconnected hexagonal cells. The cells are dark and have a slightly irregular, crystalline appearance. The overall texture is highly regular and repetitive.

1. Introduction

1. Introduction

5G or “Fifth Generation” is a commercial reality with approaching one hundred and fifty network deployments worldwide. It is a force central to the development of the Fourth Industrial Revolution. 5G technologies are a major driver for a dizzying array of groundbreaking digital services and changes that will sweep across the world over the next decade. The transition to 5G is transforming our lives, our economy, our jobs, and our industries as evidence emerges each day.

For instance, wearables, such as cellular smart watches or connected glasses, are evolving to become self-contained mobile computing devices. Autonomous vehicles, one of the most highly anticipated 5G technologies, are expected to help us reclaim commute time for new activities in our lives. Healthcare is changing as services like remote monitoring and telemedicine provide new opportunities for care. Drones will be used for transportation, surveillance, and rescue operations. Robots and Artificial Intelligence (AI) will create new dynamics for both humans and machines. Cellular Vehicular-to-Everything (C-V2X) connectivity is expected to save lives and increase transportation efficiency. Automated end-to-end manufacturing processes enabled by 5G connectivity will change the supply chain process in ways we have not witnessed since Henry Ford’s day.

The scale of 5G’s impact is expected to be staggering. One glance at industry-analyst forecasts provides us with some insight:

- **5 Billion people forecast to be accessing the internet via mobile by 2025**
- **5G coverage will roll out rapidly to cover 37 percent of the global population by 2025**
- **5G will account for 29 percent of all connections by 2025**
- **10.3 Billion mobile connections are forecast by 2025**
- **25 Billion Internet of Things (IoT) devices globally in 2025 [1]**
 - » *(11.4 Billion Consumer IoT; 13.7 Billion Industrial IoT)*
- **5G will add \$2.2 Trillion to the global economy over the next 14 years**

These are clearly enormous numbers. While the promise of 5G is high, analysts believe the expected results from 5G technology commercial deployments are in the initial development stages and will take time to evolve. The 5G architecture is standardized for today and tomorrow’s network evolution. The wireless industry is transformational using technology enablers like Cloud-Native, Software Defined Radio, Network Function Virtuality and Multi-Access Edge Computing (MEC). The mega-networks of billions of connected things and people of the future will require a major shift in network operations and management.

These changes are being enabled through the Long-Term Evolution (LTE) and 5G specifications created by hundreds of contributing scientists and engineers at the Third Generation Partnership Project (3GPP). This white paper will provide you with some additional background into what 3GPP currently has in store for the more near-term evolution for LTE and 5G. It will also touch upon the longer-term evolution of wireless communication into a possible 6G era in the coming decade.

For a more detailed look at what is anticipated for Future Networks here is the 5G Americas White Paper “[Mobile Communications Beyond 2020 – 5G Evolution Towards the Next G](#)”. This paper details the global work of conceptualizing anticipated continued enhancements, and the evolution of 5G and beyond into the future. It includes comments as appropriate and presents potential use cases and technologies for the evolution of 5G towards the next Generation.



2. Background

2. Background

The 3rd Generation Partnership Project (3GPP) unites seven telecommunications standard development organizations (ARIB, ATIS, CCSA, ETSI, TSDSI, TTA, TTC), known as “[Organizational Partners](#)” and provides their members with a stable environment to produce the reports and specifications that define 3GPP technologies.

The project covers cellular telecommunications technologies, including radio-access, core network and service capabilities, which provide a complete system description for mobile telecommunications. These 3GPP specifications also provide hooks for non-radio access to the core network, and for interworking with non-3GPP networks. 3GPP specifications and studies are contribution-driven, by member companies, in Working Groups and at the Technical Specification Group (TSG) level.

The 3GPP technologies from these groups are constantly evolving through generations (“G’s”) of commercial cellular / mobile systems. With LTE, LTE-Advanced, LTE-Advanced Pro and 5G work, 3GPP has become the focal point for most mobile systems beyond 3G.

Although these Generations have become an adequate descriptor for the type of network under discussion, real progress on 3GPP standards is measured by the milestones achieved in particular [Releases](#). New features are “functionality frozen” and are ready for implementation when a Release is completed. 3GPP works on several Releases in parallel by starting future work well in advance of the completion of the current Release. Although this adds some complexity to the work of the groups, this method ensures that progress is continuous and stable. This white paper provides a summary of the progress of the 3GPP technical features.

2.1 Global Market Trends

At the end of October 2020, there were 9.4 billion mobile connections globally, 61% of which were LTE. With 5.82 billion LTE connections, it vastly surpasses previous technologies of HSPA (1.8 billion) and GSM (1.4 billion) as the leader in global technologies.

5G network connection numbers are surging with 229 million 5G subscriptions and 236 million projected for the end of the year. This number is expected to increase to 1 billion by 2022 and over 3 billion at the end of 2025 [1], which represents up to 37% of the world’s population. The first 5G smartphones were launched in December 2018 to coincide with the launch of 5G networks in South Korea which was the beginning of the initial device wave. The volume-device wave currently has 100 5G device models that use varied combinations of High-band, Mid-band or Low-band spectrum. Performance optimized 5G devices should be available in 2021. All of this will contribute to rapid adoption and rapid growth of the 5G networks.

**LTE & 5G Connections Forecast
2020 - 2024**

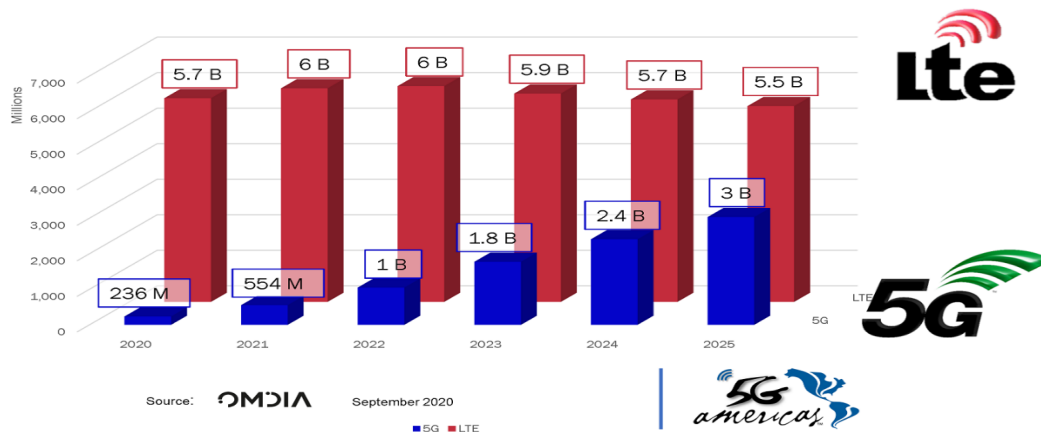

Fig. 2.1. LTE & 5G Connections Forecast – 2020 – 2024.

Figure 2.1 shows the forecast growth of both LTE and 5G technologies with LTE reaching a peak of 6 billion connections in 2021 and 2022 before beginning to slowly decline as 5G gains more popularity.

Overall, 5G network deployment is growing far more rapidly than any other previous generation. A total of 145 commercial 5G networks have already been deployed as of December 15, 2020, with 185 commercial networks forecast by the end of the 2020.

REGION	DEPLOYED	2020 FORECAST	2021 FORECAST	2022 FORECAST	2023 FORECAST
Africa	4	6	18	18	18
Asia & Pacific	39	52	73	79	80
Eastern Europe	21	24	44	47	47
Latin America & Caribbean	11	11	25	27	27
Middle East	15	22	28	28	28
U.S. & Canada	10	9	10	11	11
Western Europe	46	61	79	80	80
Total end of 2020 (forecast)	145	185	277	290	291

Fig. 2.2. 5G Deployments completed and forecast – region and global totals.

In addition to mobile subscriptions, fixed wireless access (FWA) subscriptions and cellular IoT connections are also increasing. There are currently approximately 1.5 billion cellular IoT connections, which are expected to increase to more than five billion in 2025.

Massive IoT primarily consists of wide-area use cases, connecting large numbers of low-complexity, low-cost devices that have long battery life and relatively low throughput. NB-IoT and LTE-MTC technologies complement each other.

Region	NB IoT	LTE-M
Africa	2	0
Asia & Pacific	20	10
Eastern Europe	19	0
Latin America & Caribbean	2	3
Middle East	5	1
U.S. & Canada	3	5
Western Europe	19	9
Totals	69	27
	84	



Source: TeleGeography
Publication: GlobalComms Database

December 15, 2020



Fig. 2.3. NB IoT and LTE-MTC deployments by Global Region.

Currently, the majority of cellular IoT connections still rely on 3G technology. This technology will play a substantial part by 2025, with massive-IoT based on NB-IoT and LTE-MTC devices predicted to constitute more than 40% of all cellular IoT connections. Broadband IoT is characterized by wide-area use cases requiring higher throughput, lower latency, and larger data volumes. It will contribute nearly 34%, with 4G/LTE connecting the majority of this. Critical-IoT with requirements on extremely low latency and ultra-high reliability will contribute only a small fraction to the total cellular IoT connections even in 2025.

2.2 Extension to New Use Cases

Extending new use cases beyond initial mobile broadband use cases is a main component of not only the wireless access evolution, but also the evolution of LTE and the new 5G NR (New Radio) radio-access technology. This includes massive MTC (machine type communication) use cases characterized by requirements on very low device cost and very long device battery life, often also associated with a requirement on very-wide-area coverage.

It also includes critical MTC applications, such as industrial process automation and manufacturing, energy distribution and intelligent transport systems. These applications are typically associated with requirements for very high communication reliability and the possibility for very low latency. In the standardization community, both within 3GPP and the International Telecommunications Union (ITU), critical MTC applications are often referred to as Ultra-reliable low-latency communication (URLLC).

For information on the plethora of possible new use cases refer to 5G Americas White Paper, [5G Services Innovation, 2019](#).

2.3 3GPP TimeLine

3GPP uses a system of parallel “Releases” which provide developers with a stable platform for the implementation of features at a given point and then allow for the addition of new functionality in subsequent Releases. Figure 2.4 illustrates the timeline for the most recent and near-time-future 3GPP Releases.

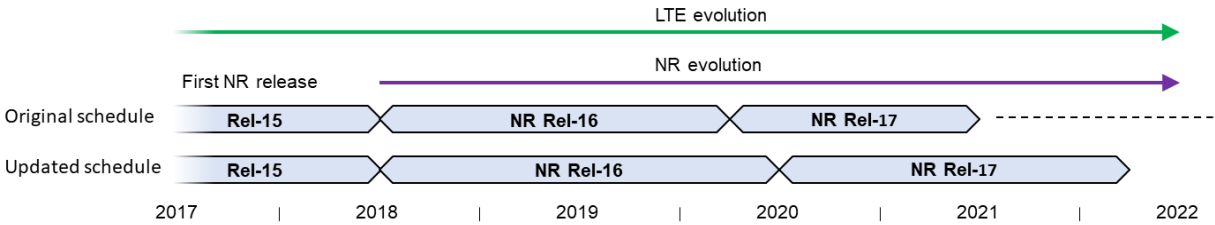

Fig. 2.4. 3GPP timeline for Release 15, 16, and 17.

Release 15, finalized in June 2018, included the first version of the 5G/NR technology, together with a set of new features as part of the LTE evolution. Release 16 included several major enhancements and extensions to NR as part of the first step in the NR evolution, together with additional LTE extensions and enhancements. Finalization of Release 16 was initially targeted for March 2020, with the physical layer specifications already finalized in December of 2019. However, the overall finalization was delayed by one quarter due to the Covid-19 situation, which has prevented 3GPP face-to-face meetings for the majority of 2020. The content of Release 16 is described in more details in Section 3.1.2 and 3.2.2 for LTE and NR respectively.

Release 17 is the main 3GPP activity for the later part of 2020 and for 2021. Release 17 was initially targeted for finalization in July 2021. However, the finalization of Release 17 has been delayed by a half year, as was decided by 3GPP RAN in December 2020. The content of Release 17 is described in more details in Section 3.1.3 and 3.2.3 for LTE and NR respectively.

2.4 ITU-R and the 3GPP IMT-2020 Submission

The ITU allocates global radio spectrum and satellite orbits, developing the technical standards that ensure that networks and technologies can seamlessly interconnect, and strives to improve access to information and communications technologies to underserved communities worldwide. Since the emergence of 3G mobile communication, each generation of wireless communication has been associated with a specific International Mobile Telecommunications (IMT) technology within ITU-R, the ITU Radiocommunication Sector.

Beginning in 2000, 3G wireless access corresponded to IMT-2000, the global standard for 3G that opened the way to enabling innovative applications and services (e.g. multimedia entertainment,

infotainment and location-based services, among others), while 4G wireless access corresponds to IMT-Advanced. Finalizing the 3GPP submission/proposal for IMT-2020 (the IMT technology corresponding to 5G wireless access) was a priority throughout 2019.

Figure 2.5 illustrates the ITU timeline for IMT-2020 and the corresponding 3GPP submissions. After the finalization of the IMT-2020 requirements in mid-2017, ITU-R opened up for the submission of IMT-2020 proposals. 3GPP made an initial submission to ITU in December 2017 and a final submission in June 2019. [2].

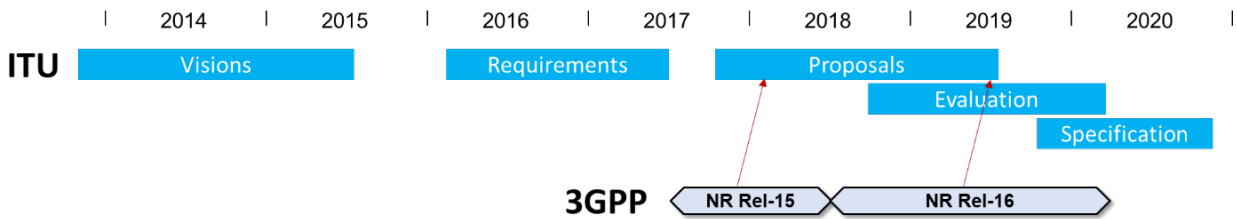

Fig. 2.5. Timeline for IMT-2020 in ITU and 3GPP submission

The overall 3GPP IMT-2020 submission consisted of two separate and independent submissions:

- **NR submitted by itself as a Radio Interface Technology (RIT) proposal for IMT-2020**
- **NR and E-UTRA/LTE jointly submitted as two component RITs of a Set of Radio Interface Technologies (SRIT) proposal for IMT-2020.**

In both cases, features up to and including 3GPP Release 16 were included in the submission.

The self-evaluation carried out by 3GPP concluded that both the NR-based RIT and the LTE/NR-based SRIT fulfill all IMT-2020 requirements for the three defined usage scenarios (eMBB, mMTC and URLLC) and for all defined test environments.



3. Radio Access Technologies

3. Radio-Access Technologies

A Radio Access Technology or (RAT) is the underlying physical connection method for a radio-based communication network. Many modern mobile phones support several RATs in one device such as Bluetooth, Wi-Fi, and GSM, UMTS, LTE or 5G NR (New Radio). With respect to this white paper, 3GPP's current areas of focus involve LTE and 5G NR.

3.1 LTE

Long-Term Evolution (LTE) is a standard for wireless broadband communication for mobile devices and data terminals, based on the GSM/EDGE and UMTS/HSPA technologies. It increases the traffic capacity and achievable data speed using a different radio interface together with core-network improvements.

3.1.1 Background

Work on the LTE radio-access technology was initiated by 3GPP in November 2004 with the first LTE specifications finalized in December 2007 as part of 3GPP Release 8. Main characteristics of the first LTE release included:

- **Support for wider transmission bandwidths up to 20 MHz**
- **Support for both frequency-division duplex (FDD) and time-division duplex (TDD), enabling operation in both paired and unpaired spectrum within the same radio-access technology**
- **Orthogonal-frequency-division-multiplexing (OFDM) based transmission scheme (conventional OFDM for downlink, DFT-pre-coded OFDM for uplink)**

- **Integrated support for downlink spatial multiplexing with up to four transmission layers to a single device**
- **Support for lower radio-access latency compared to earlier 3GPP technologies**

Since its introduction, the LTE radio-access technology has evolved in many areas with each subsequent release, leading to further enhanced performance and extended capabilities of the technology. This evolution includes:

- **Support for carrier aggregation (CA), initially supporting transmission on up to five carriers in parallel, later extended to up to 32 parallel carriers**
- **Support for operation in unlicensed spectrum by means of Licensed Assisted Access (LAA)**
- **Enhanced support for massive machine type communication by means of LTE-MTC and Narrowband IoT (NB-IoT).**
- **Direct device-to-device (D2D) communication, also referred to as sidelink communication, that is, direct communication between UEs**

For somewhat more details on the evolution of LTE up to and including Release 15, see 5G Americas' 2019 3GPP White Paper: The 5G Revolution: 3GPP Releases 16-17.

3.1.2 LTE Evolution in Release 16

3GPP Release 16 included several LTE-related features developed within six different areas.

3.1.2.1 Enhancements for LTE-MTC

LTE-MTC, sometimes also referred to as eMTC, is a low-power wide-area extension of LTE that supports IoT through lower device complexity and provides extended coverage, while allowing

the reuse of the LTE installed base.

LTE-MTC, together with NB-IoT, will continue to provide the foundation for cellular-based massive-MTC also in the 5G era. The 3GPP Release 16 work item Additional MTC Enhancements for LTE [3] introduced several new features for LTE-MTC:

- **Increased spectral efficiency for massive MTC transmissions and reduced energy consumption for massive-MTC devices, enabled by:**
 - » *Enhanced mobile-terminated early-data transmission, which can be used by idle-mode UEs to receive a small amount of data without having to transition to connected mode.*
 - » *UE-group wake-up signaling allowing the network to wake up a configurable group of UEs (instead of all UEs), thereby reducing UE energy consumption.*
 - Up to 8 groups may be configured per wake-up-signal resource.
 - » *Uplink transmission using preconfigured resources in idle mode, allowing the UE to avoid time-consuming random-access procedures.*
 - » *Multi-transport-block scheduling in both the downlink and uplink transmission directions, reducing the control-signaling overhead.*
 - Up to 8 downlink or uplink unicast transport blocks, or 8 downlink multicast transport blocks, can be scheduled using a single Downlink Control Indication (DCI).
 - » *Enhanced downlink-quality reporting from the UE in both idle and connected mode, enabling improved link*

adaptation.

- » *Relaxed serving-cell measurement requirements for low-mobility devices.*
- » *Use of resynchronization signal, introduced in Release 15, to improve performance for intra-frequency neighbor cell measurements.*
- **Improvements for ordinary LTE devices that make use of the LTE-MTC coverage enhancements. They include enabling CSI feedback for UE in-coverage enhancement, receiving ETWS/CMAS notification when a connected mode UE is in-coverage enhancement without having to release UE to idle mode, and allowing the UE to use enhanced-coverage functionality to camp in the cell.**
- **Higher efficiency in case of LTE-MTC standalone operation for cells only providing LTE-MTC access but not, for example, LTE-based mobile-broadband access. This feature allows transmissions of LTE-MTC control and data channels to extend into the unused LTE control-channel region.**

In the future, operators might migrate from LTE to NR for mobile-broadband services but may need to maintain LTE operations to provide service to legacy massive-MTC devices. In these cases, it is important to enable efficient spectrum co-existence between NR and LTE-MTC. Consequently, the 3GPP Release 16 also included analysis and performance improvements in terms of NR/LTE-MTC co-existence.

For co-existence analysis, 3GPP investigated the following issues related to LTE-MTC deployment within NR carrier – numerology,

carrier placement, channel raster, subcarrier grid alignment, synchronization, frequency band support, and RF requirements. The outcomes of the studies are captured in TR 37.823 and briefly summarized below:

- **LTE-MTC can operate in-band within NR carrier.**
- **To ensure efficient operation, the issues of numerologies, channel raster, subcarrier and resource block alignment, collision avoidance and power boosting have been addressed.**
 - » *For NR with 30 or 60 kHz SCS (i.e. mixed numerology deployment), guard-band should be used to minimize performance degradation due to loss of orthogonality. This is, however, up to network implementation and no requirement is defined.*
 - » **For NR with 15 kHz SCS -**
 - To achieve subcarrier alignment between LTE-MTC and NR, LTE-MTC carrier must be placed at specific frequency locations within NR.
 - In the downlink, LTE-MTC and NR can be aligned at the subcarrier level but not at the physical resource block level due to the presence of DC carrier in LTE-MTC. However, the number of outlying carriers can be minimized through appropriate placement of LTE-MTC carrier.
 - » **For collision avoidance between LTE-MTC and NR signals, LTE-MTC can avoid NR signals via invalid subframe and Multi-Broadcast Single-frequency Network (MBSFN) configurations, while NR can avoid LTE-MTC signals via resource reservation feature.**

NR base station is not mandated to support LTE-MTC power boosting but can do so as long as the existing RF requirements are satisfied.

For performance improvements in terms of NR/LTE-MTC co-existence, two features were specified – resource reservation and downlink subcarrier puncturing. Resource reservation allows LTE-MTC downlink and uplink resources to be reserved (i.e. not used by LTE-MTC UE) to accommodate NR signals. The reservation can be subframe, slot, or symbol level in time domain and resource block group level in the frequency domain. Downlink subcarrier puncturing allows 1 or 2 subcarriers to be punctured at the edge of a narrowband. This is to achieve resource block alignment between LTE-MTC and NR, which would otherwise not be possible due to the presence of DC in LTE-MTC.

The 3GPP Release 16 activities also included features related to enabling LTE-MTC devices to connect to the 5G core network (5GC). Key features include support of RRC_INACTIVE state, User Plane CIoT optimization in RRC_IDLE state, extended DRX, and support for early data transmission and preconfigured uplink resources.

3.1.2.2 Enhancements for NB-IoT

NB-IoT was introduced as an LTE-based radio-access technology in 3GPP Release 13 with further enhancements introduced in subsequent releases. Like LTE-MTC, NB-IoT will be a continually important tool for massive MTC and, consequently, the continued evolution of NB-IoT is also an important 3GPP activity. In fact, many Release 16 enhancements and extensions of LTE-MTC as described above were also pursued within the context of NB-IoT as part of the Release-16 work item Additional

Enhancements for NB-IoT [4]. More specifically, the work item included:

- **Increased spectral efficiency for NB-IoT transmissions and reduced energy consumption for NB-IoT devices enabled by:**
 - » *Enhanced mobile-terminated early-data transmission, which can be used by idle mode UE to receive a small amount of data without having to transition to connected mode.*
 - » *UE-group wake-up signaling by means of which the network can wake up a configurable group of UEs, thereby reducing power consumption for the UEs. Up to 8 groups may be configured per wake-up-signal resource.*
 - » *Uplink transmission using preconfigured resources in idle mode, allowing the device to avoid time-consuming random-access procedures.*
 - » *Multi-transport-block scheduling in both the downlink and uplink transmission directions, reducing the control-signaling overhead. Up to 2 downlink or uplink unicast transport blocks, or 8 downlink multicast transport blocks, can be scheduled using a single DCI.*
 - » *Enhanced downlink-quality reporting from the device in both idle and connected mode, enabling improved link adaptation.*
 - » *Presence of reference signals on non-anchor carrier for paging even when paging is not transmitted. This can be used by the UE for power saving and for improving measurements.*

- **Enhanced support for network management, including SON support for reporting of Automatic Neighbor Relation measurements, radio link failure reports and random-access configurations.**
- **Mobility enhancements by means of new system information to assist idle-mode inter-RAT cell selection for NB-IoT to and from LTE, LTE-MTC and GERAN.**

Similarly to LTE-MTC, the 3GPP Release 16 activities on NB-IoT also included co-existence analysis and performance improvements in terms of NR/NB-IoT co-existence, as well as the support for connecting NB-IoT devices to 5GC.

For co-existence analysis, 3GPP investigated the following issues: stand-alone NB-IoT operation, NB-IoT operation in NR in-band and NR guard-band, numerology, carrier placement, channel raster, subcarrier grid alignment, synchronization, frequency band support, and RF requirements. The outcomes of the studies are captured in TR 37.824 and briefly summarized below:

- **For NB-IoT operation in NR in-band, NB-IoT and NR operation can co-exist and the issues of numerologies, resource block alignment, and power boosting have been addressed.**
 - » *For NR with 30 or 60 kHz SCS (i.e. mixed numerology deployment), guard-band should be used to minimize performance degradation due to loss of orthogonality. This is, however, up to network implementation and no requirement is defined.*
 - » *For NR with 15 kHz SCS –*

- To achieve subcarrier alignment between NB-IoT and NR, NB-IoT carrier must be placed at specific frequency locations within NR.
- NB-IoT and NR resource blocks should be aligned to optimize resource allocation.
- » ***NR base station is required to support a minimum of either +3 dB or +6 dB power boosting for NB-IoT carrier depending on the NR channel bandwidth and NB-IoT carrier location.***
- » ***NB-IoT operation in NR guard-band will be handled via implementation and RF requirements will not be specified for this scenario.***

There is no co-existence issue for stand-alone NB-IoT and NR.

For performance improvements in terms of NR/NB-IoT co-existence, resource reservation on non-anchor carriers was introduced. Resource reservation allows NB-IoT downlink and uplink resources to be reserved (i.e. not used by NB-IoT UE) to accommodate NR signals. The reservation is per non-anchor carrier and can be subframe, slot, or symbol level in time domain.

The 3GPP Release 16 activities also included features related to the enabling of NB-IoT devices to connect to the 5G core network (5GC). Key features include the support of User Plane CioT optimization in RRC_IDLE state, extended DRX, and support for early data transmission. Note RRC_INACTIVE state is not supported in NB-IoT.

3.1.2.3 DL MIMO Efficiency Enhancements

One of the important enabling features of LTE-Advanced to meet IMT-Advanced downlink performance requirements is multi-user MIMO, where a transmitter serves multiple users simultaneously on the same frequency resource, primarily relying on spatial separation. DL MIMO refers to MIMO focused on downlink performance.

By means of the Enhanced Beam forming/ Full-Dimension-MIMO (EB/FD-MIMO) feature of 3GPP Release 13 and Release 14, LTE already included support for efficient massive MIMO. However, in order to enable the full potential of LTE EB/FD-MIMO, additional enhancements were introduced as part of 3GPP Release 16. More specifically, the Release-16 work item DL MIMO Efficiency Enhancements for LTE [5] enhanced the capacity and coverage of SRS (Sounding Reference Signal) transmission targeting massive MIMO for LTE TDD by means of:

- **Possibility for SRS transmission over more than one uplink symbol per subframe enabling improved SRS capacity (SRS transmission of different UEs in different symbols) as well as extended SRS coverage (SRS transmission of a single UE over multiple symbols, that is, over longer time).**
- **Introduction of the concept of virtual cell ID for SRS, enabling further improved SRS capacity by allowing different UEs within the same physical cell to occupy the same SRS time-frequency resource and instead be separated in the code domain by the use of different SRS sequences.**

3.1.2.4 Mobility Enhancements

As part of 3GPP Release 14, LTE handover latency was improved/reduced by introducing RACH-less handover and Make-Before-Break handover solutions. However, RACH-less handover was only applicable when the current uplink timing can be reused in the target cell. Furthermore, the make-before-break handover was only applicable for UEs with dual receiver chains. Thus, even with the Release-14 enhancements, a non-negligible handover interruption time still existed in many important scenarios.

For these reasons, additional LTE mobility enhancements were introduced in 3GPP Release 16 as part of the work item Even further Mobility enhancement in E-UTRAN [6].

An improved handover procedure known as “enhanced make-before-break handover”, or Dual active protocol stack (DAPS) was specified to reduce handover interruption time. DAPS reduces interruption during handover to close to 0 ms by maintaining the source cell-radio link (including data flow) while establishing the target-cell radio link.

A conditional-handover procedure was also specified as part of Release 16 to improve handover robustness. At conditional handover, the handover command is transmitted with a triggering condition in advance to avoid poor cell-edge radio conditions. The handover command may include more than one potential target cell. When the triggering condition for a potential target cell is fulfilled, the UE executes the handover to that particular target cell.

Note that similar functionality was introduced for NR Release 16, see Section 3.2.2.5.

3.1.2.5 Further Performance

Enhancements in High-Speed Scenario

The 3GPP Release-14 work item Performance enhancements for high-speed scenario in LTE improved the mobility and throughput performance under high-speed scenarios up to and above 350 km/h, by enhancing the requirements for UE Radio Resource Management (RRM), UE demodulation, and base-station demodulation.

The Release16 work item Further performance enhancement for LTE in high-speed scenario [7] extended the enhancements relative to Release 14 including:

- **Extending to even higher speed (up to 500 km/h), targeting, for example, very-high-speed trains**
- **Extending the enhanced RRM/demodulation requirements to the carrier-aggregation scenario (Release 14 only considered the non-carrier-aggregation scenario).**

3.1.2.6 LTE-Based 5G Terrestrial Broadcast

Multimedia Broadcast Multicast Services (MBMS) is a point-to-multipoint interface specification for existing and upcoming 3GPP cellular networks, which is designed to provide efficient delivery of broadcast and multicast services, both within a cell as well as within the core network. For broadcast transmission across multiple cells, it defines transmission via single frequency network configurations. The specification is referred to as Evolved Multimedia Broadcast Multicast Services (eMBMS) when transmissions are delivered through an LTE network. eMBMS is also known as LTE Broadcast.

In order to fully satisfy the 5G requirements for dedicated broadcast, Release 16 introduced additional numerologies for the PMCH (Physical Multicast Channel), that is, the physical channel used for MBMS data transmission. This included:

- **New numerology with a cyclic prefix of 300 μ s and a core OFDM symbol duration of 2.7 ms targeting rooftop reception in MPMT (Medium-Power/Medium-Tower) and HPHT (High-Power/High-Tower) scenarios.**
- **New numerology with 100 μ s cyclic prefix and 400 μ s core symbol duration for support of mobility up to 250 km/h.**

3.1.3 Further LTE Evolution in Release 17

With regards to LTE, the Release-17 activities will be relatively limited due to the growing maturity of the LTE radio-access technology. Currently, the only agreed-upon Release-17 work item on LTE will focus on further enhancements in the areas of LTE-MTC and NB-IoT, in line with the expected long-term use of LTE-based technology to serve massive-MTC applications [8]. The aim is for further broadening of the use cases for cellular LPWA and to address lessons drawn from existing deployments and trials. The work item will include supporting 16-QAM modulation for NB-IoT, increasing maximum downlink transport block size to 1736 bits (from 1000 bits) for Cat-M1 LTE-MTC UE, and the possibility for 14 HARQ processes for half-duplex LTE-MTC where, in all cases, the aim is to enable higher peak data rates. The work item will also include the support for faster recovery from radio link failures and enhanced NB-IoT carrier selection.

Separately, 3GPP will carry out a study on the possibility and required specification updates to support NB-IoT and LTE-MTC on non-terrestrial networks [9]. The aim of this possible specification would be to provide IoT connectivity in very remote areas with low or no cellular connectivity.

3.2 New Radio (NR)

5G New Radio (NR) is the global standard for a unified, more capable 5G wireless air-interface. It delivers significantly faster and more responsive mobile broadband experiences and extend mobile technology to connect and redefine a multitude of new industries.

3.2.1 NR - Background

Technical work on the NR radio-access technology was initiated in 3GPP in the spring of 2016 based on a kick-off workshop in the fall of 2015. The first NR specifications, limited to non-stand-alone operation where the NR carrier always operates together with an LTE carrier, was finalized in December 2017, with stand-alone operation supported in the June-2018 version of Release 15.

A main characteristic of NR is the substantial expansion in terms of the range of spectrum in which the radio-access technology can be deployed, with operation from below 1 GHz up to more than 40 GHz supported already in the first NR release [10]. This spectrum flexibility is enabled by a scalable OFDM numerology and inherent support for massive beamforming.

Other key features of the first release of NR included:

- **Further reduced latency (compared to, for example, LTE), enabled by:**
 - » *Shorter slots*
 - » *Possibility for transmission over part of a slot, sometimes referred to as “mini-slot” transmission*
 - » *Faster Hybrid-ARQ retransmissions*
- **Significantly more “lean” transmission, for example, due to significantly less always-on signals, leading to higher spectral efficiency as well as enabling higher network energy performance**
- **Possibility for tight interworking with LTE including LTE/NR dual-connectivity (simultaneous connectivity via LTE and NR) as well as spectrum co-existence (the possibility to deploy NR on top of LTE in the same spectrum). The latter is enabled by the OFDM-based transmission scheme with an LTE-compatible (15-kHz-based) numerology**

3.2.2 NR Evolution in Release 16

Work on NR Release 16 was initiated in the summer of 2018, with the Release 16 specifications being frozen in July 2020. While Release 15 was revolutionary for introducing a brand-new air-interface. Release 16 was the starting point for the further evolutionary development of NR.

The features introduced as part of NR Release 16 can be roughly divided into two groups, as seen in Table 3-1:

- **Features targeting new verticals such as the transport industry, industrial IoT, manufacturing, enterprise, automobile, etc.**
- **Features targeting enhanced capacity and improved the operational efficiency more generally.**

Table 3-1. Main Features of NR Release 16.

Vertical Expansion		Capacity and Operational Efficiency Enhancement	
<ul style="list-style-type: none"> • IIoT (Industrial IoT) • URLLC • 2-Step RACH 	<ul style="list-style-type: none"> • NR Positioning • NR Unlicensed • V2X 	<ul style="list-style-type: none"> • MIMO Enhancements • MR-DC • Integrated Access and Backhaul (IAB) 	<ul style="list-style-type: none"> • Mobility Enhancements • cross link interference (CLI)/remote interference management (RIM) • UE Power Savings

3.2.2.1 MIMO Enhancements

Release-15 NR introduced a scalable and very flexible MIMO framework that can be further enhanced in later releases. The Release 15 MIMO framework supported MIMO across sub-6GHz frequencies and mmWave frequencies, with a plethora of antenna elements and different transceiver architectures

supporting digital, hybrid, and analog transceivers. The Release-15 MIMO framework introduced the following capabilities:

- **Support of beam-based operation, which is required for operation in mmWave spectrum**
- **Scalable and flexible CSI codebook with up to 32 ports and an RS design including CSI-RS, DMRS and SRS.**
- **CSI type I codebook targeting single-user MIMO (spatial multiplexing) with up to eight layers.**
- **CSI type II (high resolution) codebook targeting multi-user MIMO with up to two layers per device.**

As part of the work item Enhancements on MIMO for NR [11], Release 16 provided the following MIMO-related enhancements/extensions:

Enhanced CSI type II codebook

The basic principle of the Release-16 Type II CSI is the same as that of the Release 15 Type II CSI, that is, the reporting of a set of beams on a wideband basis together with the reporting of a set of combining coefficients on a more narrowband basis. For the Release-15 Type II CSI, the combining coefficients are reported separately for each sub-band. An important feature of the Release-16 enhanced Type II CSI is therefore the possibility to utilize correlations in the frequency domain to reduce the reporting overhead, an overhead which is the main obstacle of the Release-15 Type II CSI. At the same time, the Release-16 Type II CSI allows for a factor of two improvement in the frequency-domain granularity of the PMI (Precoder Matrix Indicator) reporting. The enhanced CSI type II codebook also allows

for up to four layers per device, compared to a maximum of two layers per device for the Release-15 Type II codebook.

Enhanced multi-TRP transmission

Multi-TRP transmission implies that downlink data transmission (the PDSCH physical channel) is transmitted simultaneously from two geographically separate points. There are several potential advantages with multi-TRP transmission

- **It provides a possibility to increase the overall transmission power available for downlink transmission to a single device by utilizing the total power available at multiple transmission points**
- **It provides a possibility to extend the overall rank of the channel when the rank from a single transmission point is limited, for example, due to line-of-sight propagation conditions**

There are two different approaches to multi-TRP transmission specified as part of Release 16, see also Figure 3.1.

- **Single-DCI-based transmission, in which case a single DCI schedules a single multi-layer PDSCH where different PDSCH layers may be transmitted from different transmission points**
- **Multi-DCI-based transmission, in which case there are two separate PDSCHs, with corresponding separate DCI, being transmitted from the two transmission points. In this case, the number of layers of each PDSCH is limited so that the total number of layers of the two PDSCHs still does not exceed eight.**

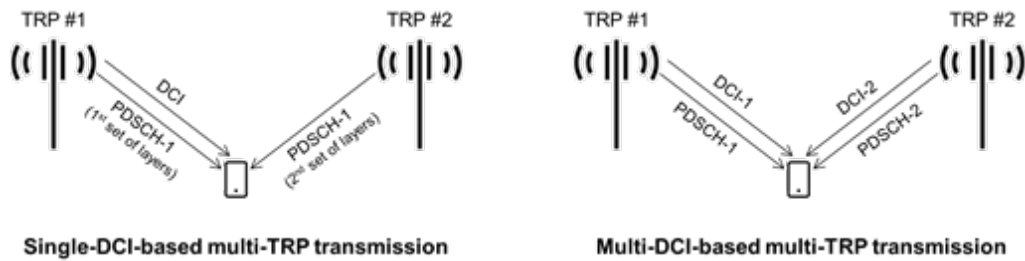

Fig. 3.1. Single-DCI-based vs. multi-DCI-based multi-TRP transmission

Multi-beam enhancements

The Release-16 enhancements related to multi-beam transmission mainly deal with features targeting reduced signaling overhead for the update of PUCCH/SRS spatial relations and PUSCH/SRS path-loss references.

In NR Release 15, the spatial relation for PUCCH, that is, the association between a given PUCCH resource and a corresponding downlink reference signal (CSI-RS or SSB), is updated per PUCCH resource, despite the fact that the all PUCCH resources of a UE would typically have the same spatial relation, that is, be associated with the same downlink reference signal. To reduce the signaling overhead for updating of the PUCCH spatial relation, Release 16 introduced PUCCH resource groups allowing for the spatial relation of multiple PUCCH resources to be updated simultaneously using the same MAC Control-Element (MAC-CE).

Release 16 also introduced the possibility to update the spatial relation for an aperiodic SRS using MAC-CE, while, for Release 15, the SRS spatial relation could only be configured by means of heavier RRC signaling. A similar enhancement was introduced for the signaling of path-loss reference for uplink PUSCH and SRS transmissions. In Release 15 the path-loss reference could only be updated by means of RRC while Release 16 introduced the possibility to update the path-loss reference means of MAC-CE.

Finally, Release 16 introduced the possibility for a default spatial relation for PUCCH/SRS, removing the need to configure/activate/update the PUCCH and SRS spatial relations in many cases.

3.2.2.2 Integrated Access and Backhaul

Integrated Access Backhaul or IAB, first introduced as part of NR Release 16, extends NR to support wireless backhaul, that is, wireless connectivity between network nodes, in addition to the conventional access link between base station and devices, see Figure 3-2.

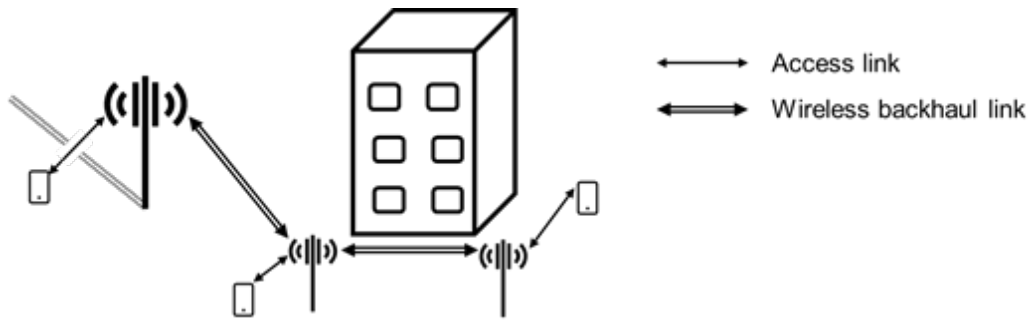

Fig. 3.2. Integrated Access Backhaul (IAB)

IAB supports both out-of-band and in-band backhauling where, in the latter case, the wireless-backhaul links and access links operate on the same carrier frequency or at least within the same frequency band. To support in-band backhauling, IAB includes tools to coordinate the use of the access and backhaul links of an IAB node thereby avoiding severe interference between them.

The overall architecture for IAB is based on the CU/DU split of the gNB, introduced already in 3GPP Release 15. According to the CU/DU split, a gNB consists of two functionally different parts with a standardized interface in between.

- **A Centralized Unit (CU) including the PDCP and RRC protocols**
- **One or several Distributed Units (DUs) including the RLC, MAC, and physical-layer protocols**

The standardized interface between the CU and a DU is referred to as the F1 interface. The specification of the F1 interface only defines the higher-layer protocols, for example, the signaling messages between the CU and DU, but is agnostic to the lower-layer protocols. With IAB, the NR radio-access technology (the RLC, MAC, and physical layer protocols,) together with some IAB-specific protocols, provides the lower-layer functionality on top of which the F1 interface is implemented.

IAB specifies two types of network nodes, see also Figure 33 below:

- **The IAB donor node consists of CU functionality and DU functionality and connects to the remaining network via non-IAB backhaul, for example fiber-based backhaul. A donor node DU may, and typically will, serve devices, like a conventional gNB, but will also serve wirelessly connected IAB nodes.**
- **The IAB node is the node relying on IAB for backhaul. It consists of DU functionality serving UEs as well as, potentially, additional IAB nodes in case of multi-hop wireless backhaul. At its other side, an IAB node includes so-called IAB-MT functionality providing connectivity with the DU of the parent node of the IAB node. Note that the parent node could either be an IAB donor node or another IAB node in case of multi-hop backhauling.**

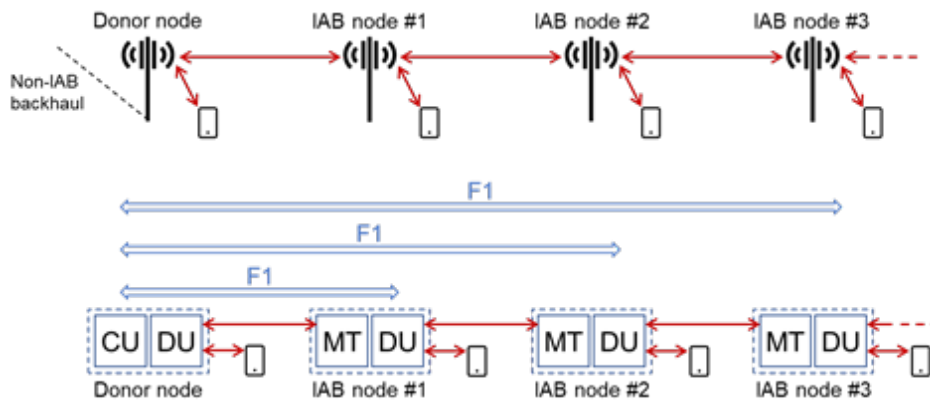

Fig. 3.3. Types of Network Nodes.

The MT connects to the DU of the parent node essentially as a normal device. The link between the parent node DU and the MT of the IAB node then provides the lower-layer functionality on top of which the F1 messages are carried between the donor-node CU and the IAB-node DU.

Figure 34 illustrates the IAB protocol stack (for the User plane, the Control plane has a similar structure).

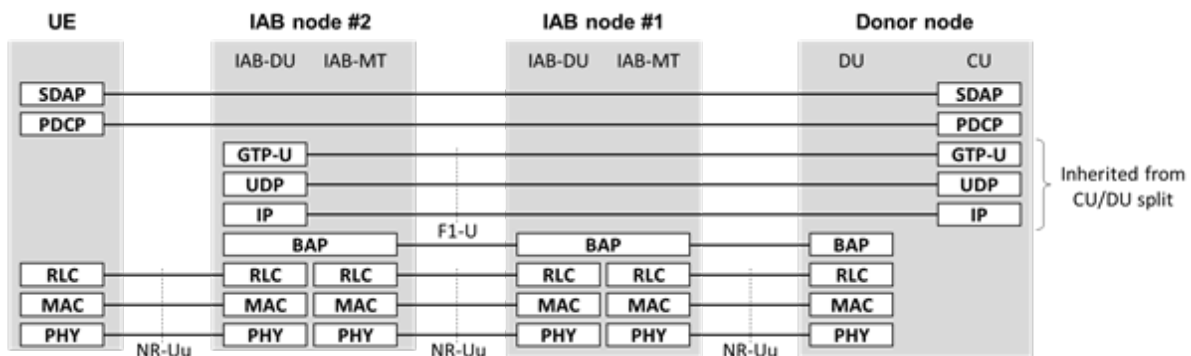

Fig. 3.4. IAB protocol stack - U-plane

The upper part of the protocol stacks is directly inherited from the general CU/DU split. The layers below are then providing the channel on top of which the F1 interface is implemented.

The lower three layers, up to an including the RLC protocol, are based on the normal NR Uu interface with some IAB-specific extensions.

The BAP or Backhaul Adaptation Protocol is a new IAB-specific protocol responsible for the routing of packets from the donor node to the target IAB node (IAB node #2 in this case) and vice versa.

In most respects, the IAB link, the link between a parent node DU and a corresponding child-node MT, operates as a conventional network-to-device link. Consequently, the IAB-related extensions to the NR physical, MAC, and RLC layers are relatively limited and primarily deal with the need to coordinate the IAB -node MT and DUs for the case when simultaneous DU and MT operation is not possible. Another important feature of the IAB link is the support for over-the-air (OTA) timing alignment, that is, the

possibility to align the DU transmission timing of different IAB nodes purely based on signals received from their respective parent nodes.

3.2.2.3 Cross Link Interference/Remote Interference Management

In an NR system operating in unpaired spectrum using time-division duplex, there may be downlink-to-uplink interference (a base-station downlink transmission interfering with the uplink reception of another base station) as well as uplink-to-downlink interference (a UE uplink transmission interfering with the downlink reception of another UE). The classical way to avoid such cross-link interference in a TDD-based mobile communication system is to apply system-wide inter-site time synchronization/alignment in combination with aligned downlink/uplink configurations between cells.

The issue of downlink-to-uplink (base-station-to-base-station) interference is especially pronounced in macro-deployments with high base-station transmit powers and over-the-roof-top base-station antennas. In small-cell deployments base stations and devices are more similar in terms of output power and antenna locations, and the impact of downlink-to-uplink interference is more similar to conventional uplink-to-uplink (UE-to-base-station) interference present in any cellular system. In such a deployment, the critical cross-link interference is the uplink-to-downlink (UE-to-UE) interference. To allow for more flexible allocation of downlink/uplink resources, Release 16 introduced enhancements to at least partly handle such cross-link interference. These enhancements consist of specified interference measurements and related reporting at the device side, together with

specified inter-gNB signaling enabling inter-site coordination based on, for example, such reported measurements.

More specifically, the Release 15-RSRP (reference-signal received power) measurements/reporting has been extended to include the possibility for UE measurements/reporting of RSRP also of SRS transmissions of other UEs. In this way, the network can acquire knowledge about the potential UE-to-UE interference between UEs of different cells.

The specified inter-gNB signaling allows for gNBs to announce fixed and flexible resources where a fixed resource is assumed to be used in a certain direction only while a flexible resource imply that the signaling gNB may use the resources in either transmission direction (uplink or downlink). With this knowledge about the fixed/flexible-resource configuration of neighboring gNBs, a gNB may schedule more sensitive transmissions in a fixed resource, where the transmission direction and hence the interference characteristics are known, while Flexible resources can be used for less critical data for which occasional retransmissions due to strong UE-to-UE interference is less of an issue.

In addition to the enhancements in terms of handling UE-to-UE cross-link interference described above, typically targeting small-cell deployments and with the aim to enable more flexible resource utilization. NR Release 16 also includes tools for so-called remote-interference management (RIM). This targets large macro-cell deployments where, even though system-wide time synchronization/alignment and common DL/UL configurations are used, downlink-to-uplink

(base-station-to-base-station) interference may still occur due to very large propagation delays. Such propagation delays may occur due to a phenomenon known as ducting which occurs due to higher layers of the atmosphere having lower density and therefore a lower refractive index, compared to lower layers. This reflects electromagnetic waves, ultimately sending the transmitted signal much farther (see Figure 3.5).

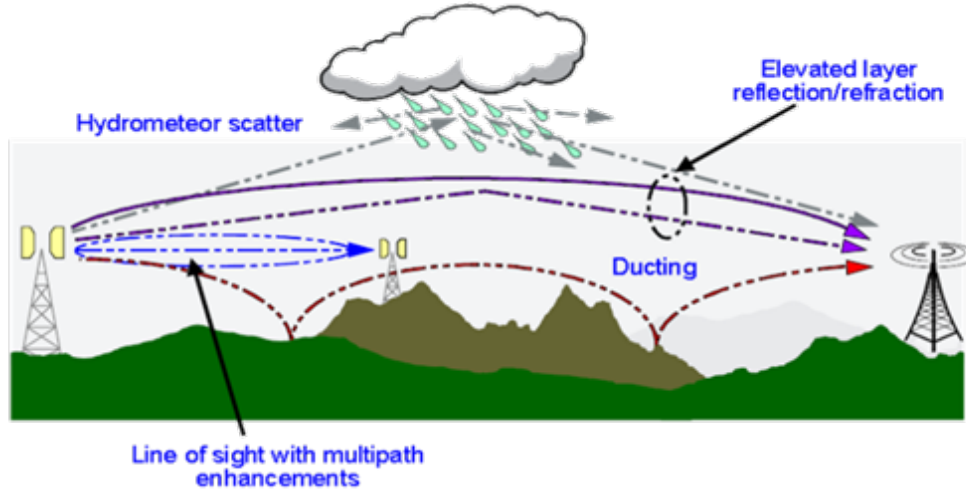

Fig. 3.5. Remote interference 100's of kms away caused by ducting.

The propagation delay also delays the interfering signal due to the large propagation distance and may exceed the guard period. Consequently, the downlink transmission of the aggressor may severely interfere with the uplink reception at the victim, see Figure 3.6.

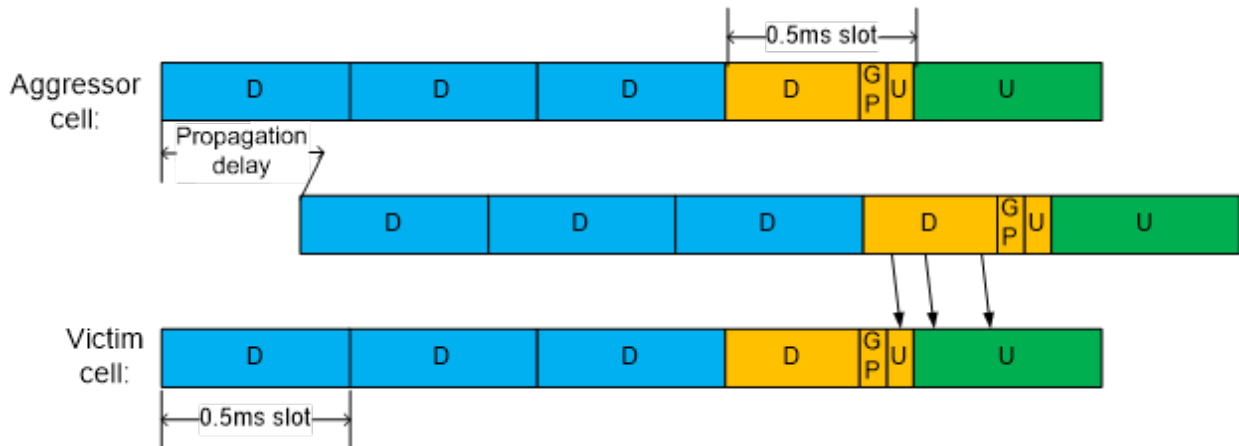

Fig. 3.6. Single of aggressor cell arriving delayed at victim cell such that downlink of aggressor cell interferes with uplink of victim cell.

To mitigate remote interference, Release 16 introduced two new RIM-reference signals to indicate and detect the presence of remote interference.

- **RIM-RS type 1** is transmitted by a victim cell and is used to signal that remote interference is detected – that is, that a ducting phenomenon exists. In addition to an identity of the (group of) cells that causes the interference, it can convey information about the number of OFDM symbols at the beginning of the uplink period that is affected by remote interference.

- **RIM-RS type 2 is transmitted by the aggressor cell and is used to indicate that a ducting phenomenon exists. Unlike type 1, it does not carry any additional information.**

Various implementation schemes can then be used to mitigate the effect of remote interference when detected such as:

- **Time-domain solutions:**
 - » *The victim can avoid scheduling on UL symbols suffering from remote interference.*
 - » *The aggressor can mute/back-off or avoid scheduling on DL symbols that cause remote interference to the victim.*
- **Frequency-domain solutions**
 - » *The aggressor DL and the victim UL can be statically or semi-statically configured to transmit on mutually orthogonal frequency resources*
- **Spatial-domain solutions**
 - » *Mounting antennas at the aggressor at lower height*
 - » *The victim/aggressor gNB adjust the antenna down-tilt*
- **Power-domain solutions**
 - » *The victim gNB increases the UL transmission power*
 - » *The aggressor gNB reduces the DL transmission power on DL symbols potentially causing remote interference*

3.2.2.4 UE Power Savings

The wider NR bandwidth and the higher data rates, compared to LTE, imply a potentially higher UE energy consumption and corresponding shorter UE battery lift. Therefore,

as part of 3GPP Release 16, several new features addressing the UE power consumption in connected mode were introduced.

- **A PDCCH-based Wake-Up Signal (WUS) that the network transmits before active on-duration within DRX cycles. This allows for UEs to avoid PDCCH monitoring during on-durations within which the network is anyway not transmitting any data to the UE. It is anticipated that this may enable between 15% and 30% energy saving. Alternatively, the WUS may allow for shorter DRX cycles, that is, faster response time, with unchanged energy consumption.**
- **An extension of the Release-15 mechanisms to limit the maximum number of DL MIMO layers to include per-bandwidth-part limitations with adaptation based on traffic type and buffer status. This allows for UEs, in some scenarios, to operate with a reduced number of active receive antennas if full-rank transmission will not take place.**
- **A configurable minimum-scheduling-offset parameter, indicating the minimum time between the scheduling PDCCH and the corresponding PDSCH. For sufficiently large values of the offset parameter, the UE does not need to buffer PDSCH symbols during PDCCH decoding, enabling a reduced UE power consumption.**
- **The possibility for a UE to relax RRM measurements when detecting that it is in a low-mobility scenario and/or not at the cell border. These two scenarios are assumed to be detected from the variations in UE-measured RSRP**

and introduction of new RSRP/RSRQ thresholds respectively.

- **The possibility for a UE to signal to the network, via a UEAssistanceInformation message, that it “prefers” to be released from the RRC_CONNECTED state. This may allow for more efficient transition to IDLE or INACTIVE state when the UE does not expect further imminent DL/UL data exchange. In parallel and independently, the UE may also provide assistance to the network regarding preferred C-DRX configuration.**

3.2.2.5 Mobility Enhancements

In NR high-frequency range with beamforming, the handover interruption time can be larger than that of LTE due to beam sweeping. Furthermore, this may lead to more radio-link failures and hence less reliability. To reduce the handover interruption time and the risk for radio-link failures, two new handover-related features, conditional handover and dual active protocol stack (DAPS) was introduced as part of NR Release 16 [12].

Note that similar functionality was introduced also for LTE Release 16, see Section 3.1.2.4.

Conditional handover

With conventional handover, such as within Release 15, the network issues a handover command based on device measurement reports. Triggered by the reception of the handover command, the device executes the handover to a new (target) cell in line with the handover command. However, if the channel conditions to the current cell deteriorates too quickly, the uplink device measurement report or the downlink handover command may be lost, implying that no handover is

executed, with, typically, a radio-link failure as a consequence. The device must then make a conventional initial access to the new cell, followed by a lengthy connection set up.

In case of conditional handover, the device is prepared with one or multiple candidate target cells in advance. This is done by the device being provided with corresponding handover commands for each of a set of candidate target cells. However, in contrast to the case of conventional handover, the handover commands are not executed on reception. Rather, the handover commands are stored in the device and only executed when specific conditions are met, for example when the link quality to the current cell falls beyond a given threshold. In this way, one avoids the risk that the handover will not be executed due to rapidly deteriorating channel conditions, leading to a significantly reduced risk for radio link failures.

Dual active protocol stack

With conventional handover, the UE releases the connection to the source cell before the link to the target cell is established by means of a random access. This causes an interruption in the communication in the range of a few 10 ms, something which may not be acceptable for high reliability low-latency services.

In case of handover based on dual active protocol stack, the UE establishes a second protocol stack with separate RLC and MAC entities to the target cell while still keeping the protocol stack for the source cell. At the same time, the downlink PDCP packets are forwarded from the gNB of the source cell to the gNB of the target cell. While keeping communication

with the source cell, the UE can now initiate random access and establish a connection to the target cell. Once the connection to the target cell is established, communication can immediately switch to that cell, with essentially zero interruption time

3.2.2.6 Multi-RAT Dual Connectivity and CA Enhancements

NR Release 15 included support for

- **Carrier aggregation, with cross-carrier scheduling limited to the case of the same numerology for the scheduling carrier and the scheduled carrier**
- **Dual connectivity between two NR carriers (NR-NR DC), limited to the case of one carrier in FR1 and one carrier in FR2 and with tight synchronization between the carriers**
- **Dual connectivity between E-UTRAN and NR with either E-UTRAN as the primary cell (EN-DC) or NR as the primary cell (NE-DC).**

Release 16 introduced additional mechanism to enhance the performance of dual connectivity (DC) and CA [13].

- **Support for NR-NR DC also for the asynchronous case and for additional carrier combinations, for example, Master Cell Group (MCG) and Secondary Cell Group (SCG) with serving cells in same frequency range**
- **Early measurement reporting from neighbor and serving cells to reduce the delay when setting up dual connectivity and/or carrier aggregation.**
- **Efficient and low-latency serving-cell configuration/activation/setup by**

minimizing the signaling overhead and latency needed for cell setup and cell activation.

- **Fast recovery of MCG link when the SCG link is still operational, for example, by utilizing the SCG link and split SRBs for recovery during MCG failure.**
- **Cross-carrier scheduling of CA cells with different numerologies.**

3.2.2.7 Industrial IoT (IIoT)

The motivation for the Release-16 work item Support of NR Industrial Internet of Things [14] was to extend the applicability of NR to various verticals, such as further improvements for AR/VR and new uses cases like factory automation, transport industry and electrical power distribution. This was achieved by increasing the reliability of the Uu interface, increasing resource efficiency with duplication, better handling of high-priority traffic multiplexed with low-priority traffic in the same UE, and more efficient support of TSC.

To achieve this the following mechanisms was standardized in Release 16:

- **PDCP duplication enhancements**
 - » *Duplication with up to four copies over up to four logical channels. For carrier-aggregation-based packet duplication, the packet is sent on up to four serving cells of a single gNB. For dual-connectivity-based packet duplication, the packet is sent on serving cells belonging to two different gNBs.*
 - » *Dynamic network control of PDCP duplication activation/deactivation via MAC command.*

- RAN support for higher-layer multi-connectivity to improve reliability by introducing duplication of a PDU session.
- Intra-UE prioritization/multiplexing where UE is now able to prioritize the grants or logical channels in order to decide which grant to use.
- TSC-related enhancements like reference-timing delivery from gNB to UE, time sensitive communication assistance information, and Ethernet header compression.
- Scheduling enhancements to support up to eight simultaneously active semi-persistent scheduling configurations for a given BWP of a UE.

3.2.2.8 Ultra-Reliable Low Latency Communications (URLLC)

Release 15 provided basic URLLC functionality:

- » *Lower latency by supporting:*
- » *Higher subcarrier spacing with corresponding shorter transmission durations.*
- » *Possibility for mini-slot transmission over only a fraction of a slot.*
- » *Frequent PDCCH monitoring reducing the latency of the layer-1 control information.*
- » *Configured grant which allows the UE to autonomously transmit uplink data without having to send a scheduling request and wait for the uplink grant.*
- » *Downlink preemption.*

- Higher reliability by supporting;
 - » *Multi-slot repetition.*
 - » *Low spectral efficiency MCS/CQI tables.*
 - » *PDCP duplication.*

Release 16 further enhanced the NR support for URLLC services by enabling latency in the range of 0.5 to 1 ms and improved reliability with a target error rate of 10⁻⁶. This allows for the support of new use cases, such as factory automation and transport industry as well as improving the performance of Release-15 use cases such as AR/VR and gaming.

To achieve this, the Release-16 work item Physical Layer Enhancements for NR Ultra-Reliable and Low-Latency Communication (URLLC) [15] specified the following improvements:

- PDCCH enhancements focusing on:
 - » *Configurable field sizes for downlink control information for improved reliability.*
 - » *Increased PDCCH monitoring capability to minimize scheduling block/delay.*
- UCI enhancements focusing on:
 - » *Support of multiple HARQ-ACK-feedback occasions per slot to reduce latency. Up to 9 or 8 occasions can be configured per slot for normal and extended cyclic prefix, respectively.*
 - » *Support of two multiple HARQ-ACK codebooks with different priority levels intended for different services.*

- **PUSCH enhancements by supporting two different PUSCH repetition types:**
 - » *Type A: This is Release-15 PUSCH transmission with or without slot aggregation. This can be used to improve spectral efficiency.*
 - » *Type B: One grant can schedule two or more PUSCH repetitions that can be in one slot, or across a slot boundary in consecutive available slots. This can be used to achieve low latency.*
- **Inter-UE prioritization and multiplexing focusing on:**
 - » *UL preemption by allowing the gNB to interrupt data transmission from one user to accommodate higher-priority data from another user. A new grant is introduced for notifying the UE to cancel its uplink transmission.*
 - » *Enhanced UL power control to enable power boosting for URLLC UL transmissions overlapping with some eMBB transmission.*
- **Configured-grant enhancements by supporting up to 12 configurations, to accommodate different service flows and to reduce the alignment time for URLLC UL transmissions.**

3.2.2.9 V2X (Vehicle-to-Everything)

V2X extends the 3GPP platform to the automotive industry by providing vehicle-to-everything support to vehicles, pedestrians, infrastructure units, and the network. The V2X messages can be transferred over the Uu interface (the normal uplink/downlink interface between the base station and the UE) or directly between UEs on a sidelink interface (also known as PC5).

V2X was introduced to 3GPP in Release 14 by extending LTE to provide support for the automotive industry. Release-14 V2X supports basic road safety features by exchanging messages regarding position, speed and direction with the surrounding vehicles, infrastructure units and pedestrians. NR V2X, introduced as part of 3GPP Release 16, is designed to complement and interwork with LTE V2X by supporting more advanced use cases, grouped into four areas:

- **Vehicle platooning is the ability of a group of vehicles traveling together to organize into a platoon, with a lead vehicle providing messages to other vehicles in the platoon allowing for smaller inter-vehicle distances**
- **Extended sensors allow for exchange of sensor data and live video between vehicles, pedestrians, infrastructure units, and V2X application servers to extend the UE's perception of the surrounding environment.**
- **Advanced driving allows for autonomous or semi-autonomous driving by exchanging sensor data and driving intention which enables vehicles to coordinate their trajectories**
- **Remote driving allows for a remote driver or V2X application to remotely drive a vehicle for passengers who can't drive themselves, or vehicles driven in dangerous environments. The main requirement for remote driving is low-latency communication.**

Although the scope of the Release-16 NR V2X work item was not limited to vehicle-to-vehicle communication but also included, for example, the required vehicle-to-infrastructure

communication for the above use cases, the absolute main part of the work-item activities focused on the introduction of NR sidelink communication targeting the vehicle-to-vehicle use case.

NR sidelink communication supports three basic transmission scenarios, see also Figure 3.7.

- **Unicast:** the sidelink transmission targets a specific receiving device.
- **Groupcast:** the sidelink transmission targets a specific group of receiving devices
- **Broadcast:** the sidelink transmission targets any device that is within the range of the transmission.

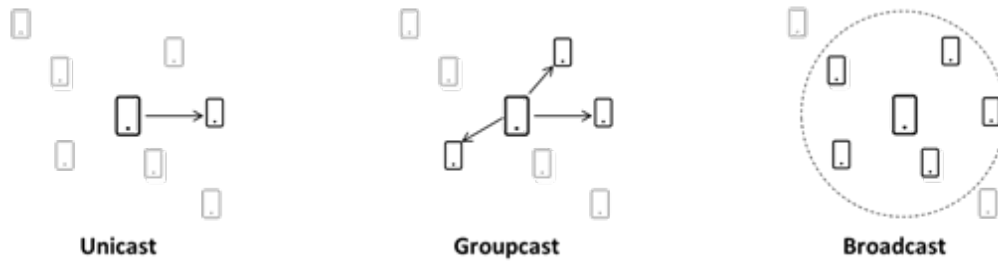

Fig. 3.7. Basic sidelink transmission scenarios

There are different deployment scenarios for NR sidelink communication in terms of the relation between the sidelink communication and an overlaid cellular network, see also Figure 3-8.

- **In-coverage operation** the devices involved in the sidelink communication are under the coverage of an overlaid cellular network. The network can then, to a smaller or larger extent depending on the exact mode-of-operation, control the sidelink communication.
- **Out-of-coverage operation** the devices involved in the sidelink communication are not within the coverage of an overlaid cellular network.

One can also envision a “partial-coverage” scenario where only subset of the devices involved in the device-to-device communication are within the coverage of an overlaid network.



Fig. 3.8. Sidelink deployment scenarios

In case of in-coverage/partial-coverage operation the overlaid network could either be an NR-based network or an LTE-based network. There is also a possibility for LTE-based sidelink operation under the coverage of an overlaid NR network.

Furthermore, in case of in-coverage/partial-coverage sidelink operation, the sidelink communication may share carrier frequency with downlink and/or uplink transmissions within the overlaid cellular

network. Alternatively, sidelink communication may take place on a sidelink-specific carrier frequency, different from the carrier frequency of the cellular network. In the former case a key aspect of sidelink communication is the ability to coordinate/control the resource usage in order to control the interference between sidelink transmissions and transmissions within the cellular network. NR sidelink communication supports two modes for the allocation of resources for sidelink transmission.

- **Resource allocation mode 1** in which case an overlaid network schedules all sidelink transmissions. The operation is similar to how a network provides scheduling grants for conventional uplink transmissions except that the scheduling grant is not for an uplink transmission but for a sidelink transmission. For obvious reasons, resource allocation mode 1 is only applicable when a sidelink device is under network coverage, that is, for the in-coverage and partial-coverage deployment scenarios.
- **Resource allocation mode 2** in which case decision on sidelink transmission, including decision on the exact set of resources to use for the transmission, is made by the transmitting device itself based on a specified sensing and resource-selection procedure. Resource allocation mode 2 is applicable to both in-coverage and out-of-coverage deployment scenarios.

3.2.2.10 NR unlicensed – NR-U

Licensed spectrum is the cornerstone of wireless mobile service to meet the service requirements for coverage, spectral efficiency, and reliability but unlicensed spectrum can play an important role in complementing licensed spectrum by boosting capacity and, in some cases, improving data connectivity.

In Release 16, NR was extended to support operation also in unlicensed spectra, with focus on the 5 GHz (5150-5925 GHz) and 6 GHz (5925 – 7150 GHz) bands (Figure 3.9). The 5 GHz band is used by existing technologies such as Wi-Fi and LTE-based LAA and it was a requirement, for the design of NR-U, or NR in unlicensed spectrum, that the impact on WiFi should not exceed that of an additional Wi-Fi network of the same generation on the same carrier. The 6GHz band is a greenfield band with regulators reviewing it for use for wireless purposes.

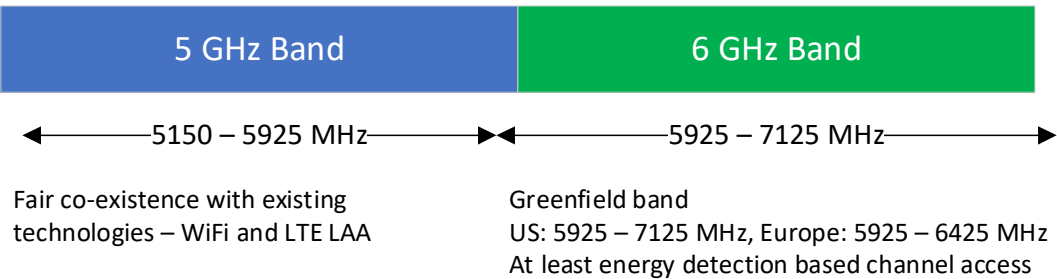

Fig. 3.9. Spectrum priorities for NR-U.

In contrast to LTE, which only supports license-assisted-access (LAA) operation in unlicensed spectrum, NR supports both LAA and stand-alone unlicensed operation, see Figure 310.

In the case of LAA, a NR carrier in unlicensed spectrum is always operating jointly with a carrier in licensed spectrum, with the carrier in licensed spectrum used for initial access and mobility. The licensed carrier can be an NR carrier, but it can also be an LTE carrier. Dual connectivity is used in case of the licensed carrier using LTE. If the licensed carrier is using NR, either dual connectivity or carrier aggregation can be used between the licensed and unlicensed carrier.

In case of stand-alone operation, an NR carrier in unlicensed spectrum operates without support of a licensed carrier. Thus, initial access and mobility are handled entirely using unlicensed spectra.

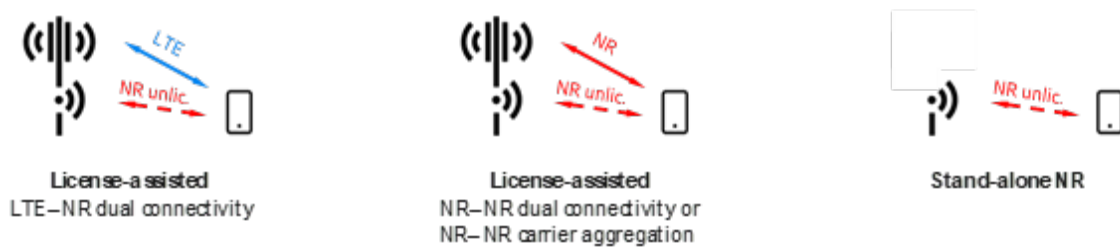

Fig. 3.10. License-assisted (left and middle) and stand-alone (right) operation of NR in unlicensed spectra.

Based on this, NR-U supports the following deployment scenarios:

- **Carrier aggregation in NR between licensed band (Pcell) and NR-U (Scell).** The NR-U Scell may have both DL and UL or just DL. The NR Pcell is connected to 5GC. This scenario improves NR capacity by adding more spectrum to NR.
- **Dual connectivity between LTE in licensed band (Pcell) and NR-U (PSCell).** This scenario improves the capacity of LTE deployments.
- **Standalone-NR-U connected to 5GC.** This scenario targets standalone deployments such as non-public networks.
- **Standalone cell in unlicensed band connected to 5GC and UL in licensed band.**
- **Dual connectivity between NR in licensed band and NR-U, with the Pcell connected to 5G-CN.** This scenario improves NR capacity by adding more spectrum to NR.

The channel-access procedure for NR-U is largely inherited from LTE LAA, except that the NR-U design is mostly based on NR Release 15 with additional enhancements for operation in unlicensed spectrum. The enhancements are necessary to fulfill regulatory requirements, like Power Spectral Density (PSD) limitations and Occupied Channel Bandwidth (OCB) in Europe, and also to compensate for reduced transmission opportunities due to LBT failure. The main enhancements are:

- **Inclusion of RMSI-CORESET(s)+PDSCH(s) (carrying RMSI) associated with SS/PBCH block(s) in addition to the SS/PBCH burst set in one contiguous burst (referred to as the NR-U DRS) to limit the required number of channel-access and for short channel occupancy.**
- **Support of new UL resource allocation (block- interlaced waveform) to satisfy the OCB requirements and PSD requirements of the 5GHz unlicensed bands in Europe.**
- **Multiple techniques to handle reduced HARQ A/N transmission opportunities due to LBT failure, including the support of gNB-triggering retransmission of HARQ-Ack/Nack feedback.**
- **Enhancements to UL scheduling, such as scheduling multiple slots for PUSCH(s) using a single UL grant.**
- **Removing dependencies of HARQ process information to the timing for configured UL transmissions. In NR-U configured UL, UE selects HARQ ID, RV, and NDI and report that as part of UCI in every configured UL PUSCH.**
- **Support of DL type-B PDSCH length from 2 to 13 symbols.**

Already during the NR-U study item it was concluded that it is feasible for NR-U to achieve fair co-existence with Wi-Fi, and for NR-U to co-exist with itself.

3.2.2.11 NR Positioning

Release 15 NR provides support for RAT-independent positioning techniques and Observed Time Difference of Arrival (OTDOA) on LTE carriers. Release 16 extends NR to provide native positioning support by introducing

RAT-dependent positioning schemes. These support regulatory and commercial use cases are more stringent requirements on latency and accuracy of positioning [16]. NR enhanced capabilities provide valuable, enhanced location capabilities. Location accuracy and latency of positioning schemes improve by using wide signal bandwidth in FR1 and FR2. Furthermore, new schemes based on the angular/spatial domain were introduced, in part to mitigate synchronization errors, by exploiting massive antenna systems.

The positioning requirements for regulatory (e.g. E911) and commercial applications are described in 3GPP TR 38.855. For regulatory use cases, the following are the minimum performance requirements:

- **Horizontal positioning accuracy better than 50 meters for 80% of the UEs.**
- **Vertical positioning accuracy better than 5 meters for 80% of the UEs.**
- **End-to-end latency less than 30 seconds.**

For commercial use cases, for which the positioning requirements are more stringent, the following are the performance targets for Release 16.

- **Horizontal positioning accuracy better than 3 meters (indoors) and 10 meters (outdoors) for 80% of the UEs.**
- **Vertical positioning accuracy better than 3 meters (indoors and outdoors) for 80% of the UEs.**
- **End-to-end latency less than 1 second.**

Figure 3.11 shows the RAT-dependent NR positioning schemes which were standardized in Release 16:

- **Downlink time difference of arrival**

(DL-TDOA): A new reference signal known as the positioning reference signal (PRS) is introduced in Release 16 for the UE to perform downlink reference signal time difference (DL RSTD) measurements for each base station's PRSs. These measurements are reported to the location server using the LTE Positioning Protocol (LPP).

- Uplink time difference of arrival (UL-TDOA): The Release 16 sounding reference signal (SRS) is enhanced to allow each base station to measure the uplink relative time of arrival (UL-RTOA) and report the measurements to the location server using the New Radio Positioning Protocol A (NRPPa).
- Downlink angle-of-departure (DL-AoD): The UE measures the downlink reference signal receive power (DL RSRP) per beam/gNB. Measurement reports are used to determine the AoD based on UE beam location for each gNB. The location server then uses the AoDs to estimate the UE position.
- Uplink angle-of-arrival (UL-AOA): The gNB measures the angle-of-arrival based on the phase difference at antenna elements of the received SRS for positioning from the UE. Measurement reports are sent to the location server over NRPPa.
- Multi-cell round-trip time (RTT): The gNB and UE perform Rx-Tx time difference measurement for the signal of each cell. The measurement reports from the UE and gNBs are sent to the location server to determine the round-trip time of each cell and derive the UE position.

- Enhanced cell ID (E-CID). This is based on RRM measurements (e.g. DL RSRP) of each gNB at the UE. The measurement reports are sent to the location server.

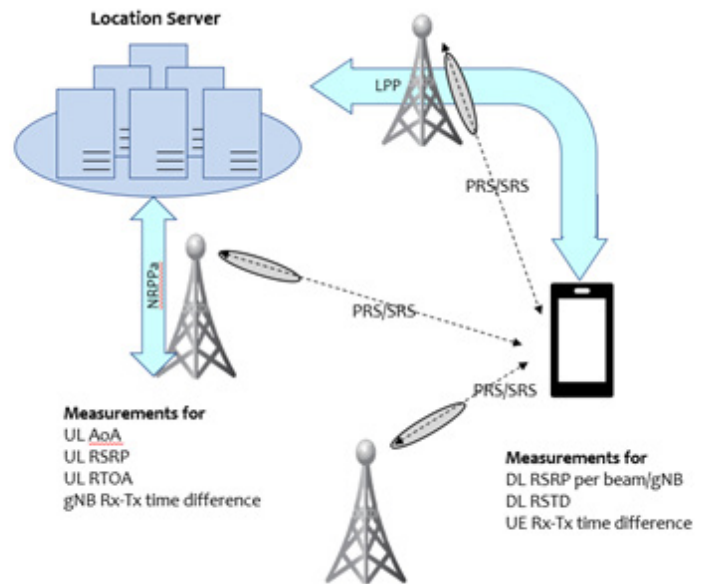

Fig. 3.11. NR RAT-dependent positioning schemes.

UE-based measurement reports for positioning:

- Downlink reference signal reference power (DL RSRP) per beam/gNB
- Downlink reference signal time difference (DL RSTD)
- UE RX-TX time difference

gNB-based measurement reports for positioning:

- Uplink angle-of-arrival (UL-AoA)
- Uplink reference signal receive power (UL-RSRP)
- UL relative time of arrival (UL-RTOA)
- gNB RX-TX time difference

NR adopts a solution similar to that of LTE LPPa for Broadcast Assistance Data Delivery, which provides support for A-GNSS, RTK and OTDOA

positioning methods. PPP-RTK positioning will extend LPP A-GNSS assistance data message based on compact “SSR messages” from QZSS interface specifications. UE-based RAT-dependent DL-only positioning techniques are supported in Release 16, where the positioning estimation will be done at the UE-based on assistance data provided by the location server.

3.2.2.12 2-Step RACH [17]

The contention-based random-access procedure of Release 15 is a four-step procedure, as shown in Figure 3.12. The UE transmits a contention-based PRACH preamble, also known as Msg1. After detecting the preamble, the gNB responds with a random access response (RAR), also known as Msg2. The RAR includes the detected preamble identity, a time-advance command, a temporary C-RNTI (TC-RNTI), and an uplink grant for scheduling a PUSCH transmission from the UE known as Msg3. The UE transmits Msg3 in response to the RAR including an identity for contention resolution. Upon receiving Msg3, the network transmits the contention resolution message, also known as Msg4, with the contention resolution identity. The UE receives Msg4, and if it finds its contention-resolution identity it sends an acknowledgement on a PUCCH, which completes the 4-step random access procedure.

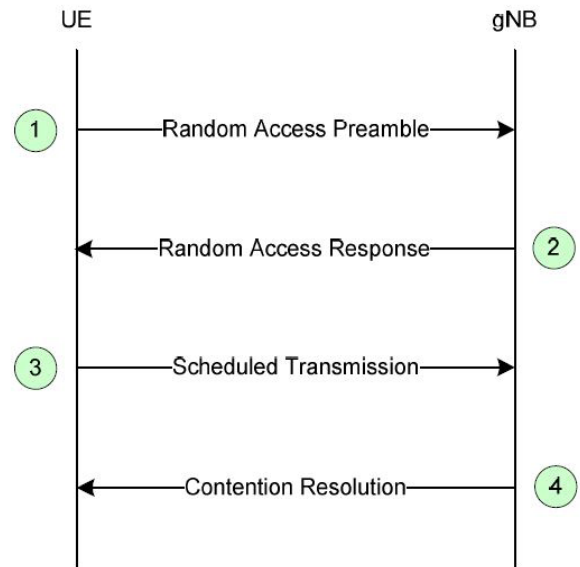

Fig. 3.12. 4-step contention-based Random-Access Procedure.

The four-step random-access procedure requires two round-trip cycles between the UE and the base station, which not only increases the latency but also incurs additional control signaling overhead. To address this, Release 16 introduced a complementary two-step random-access procedure. The motivation of the two-step random access procedure is to reduce latency and control-signaling overhead by having a single round-trip cycle between the UE and the base station. This is achieved by combining the preamble (Msg1) and the scheduled PUSCH transmission (Msg3) into a single message (MsgA) and combining the random-access response (Msg2) and the contention-resolution message (Msg4) into a single message (MsgB) from the gNB, see Figure 3.13. An additional benefit of the two-step random-access procedure is that, for unlicensed spectrum, reducing the number of messages transmitted from the UE and the gNB, reduces the number of LBT (listen-before-talk) attempts.

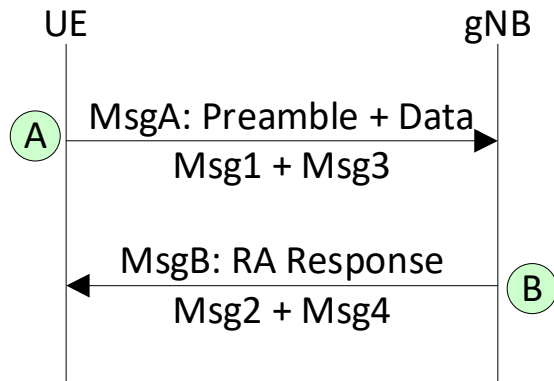

Fig. 3.13. Two-step contention based Random-Access Procedure.

The two-step random-access procedure can be applied to most of the situations to which the Release-15 four-step procedure can be applied, including initial access, mobility, SI request and re-establishment of synchronization by means of so-called PDCCH order. It should be noted that in order to support legacy (Release-15) devices, the network must always support the Release-15 four-step random-access procedure.

3.2.3 Further Evolution in Release 17

Initial discussions on the content of 3GPP Release 17 began at RAN #84 in June 2019 with final decisions on the content of Release 17 in December of 2019. Release 17 will consist of enhancements to Release 16 features, including MIMO, unlicensed access and IAB as well as an extension of operating spectrum beyond 52.6 GHz. Release 17 will also introduce support for new use cases, for example the support of reduced-capability devices for specific IoT use cases.

As already described in Section 2.3, Release 17 was initially targeted for finalization in June 2022. However, due to the delay in the 3GPP time schedule, current announcement is that Release 17 will be finalized in March 2022 with ASN.1 finalization in July 2022.

3.2.3.1 NR Beyond 52.6 GHz

NR Release 15/16 support operation in spectrum up to 52.6 GHz. As part of 3GPP Release 17, spectrum support up to 71 GHz is being studied [18]. This extension will cover the original 60 GHz band (57-66 GHz) as well as the recently identified 66-71 GHz frequency band. The study will include:

- **Study of necessary changes to NR to support operation between 52.6 – 71 GHz using existing waveform, including extension to the numerology (e.g. subcarrier spacing, channel bandwidth) and their impact.**
- **Study of channel access mechanism, assuming beam-based operation, to comply with regulatory requirements for operation in unlicensed bands.**

3.2.3.2 IAB Enhancements

Integrated Access and Backhaul networks reduce deployment costs by obviating the need to provide wired backhaul to each cellular base station. Several extensions to Release-16 IAB will be covered by a Release-17 work item on IAB enhancements [19]. The aim of this work item is to enhance Release-16 IAB in terms of robustness, spectral efficiency, latency, and end-to-end performance.

One objective of the IAB Release-17 work item is to introduce extended possibilities for multiplexing transmissions between

the backhaul and access links, that is, simultaneous DU and MT operation within an IAB node. Especially, the work item will introduce enhanced support for simultaneous MT-RX/DU-RX and/or simultaneous MT-TX/DU-TX, sometimes referred to as SDM (in case of DU/MT separation in the spatial domain, for example, by the use of different antenna panels) or FDM (in case of DU/MT separation in the frequency domain by using separate resource blocks). The work item is also considering simultaneous MT-RX/DU-TX and simultaneous DU-RX/MT-TX, often referred to as IAB-node full duplex.

These multiplexing options, which can improve IAB efficiency and reduced latency, are at least partly already possible with Release-16 IAB. However, some additional features—like new timing relations between the DU and MT part of an IAB node—will further extend the applicability of these multiplexing combinations.

The Release-17 work item also includes extended means for topology adaptation including

- **Means for enhanced robustness, load balancing and reduced service interruption time, in scenarios involving two donor node CUs**
- **Means for topology redundancy by allowing for multiple parallel paths within the IAB- based backhaul connectivity to enable enhanced backhaul robustness as well as more general topology, routing and transport enhancements for improved efficiency of deployments utilizing IAB.**

3.2.3.3 *Reduced Capability NR devices*

As already discussed, the basic massive MTC use cases, characterized by requirements on very low device cost and very low device energy consumption in combination with wide-area coverage, are assumed to be provided by means of LTE-based LTE-MTC and NB-IoT also in the 5G era. However, there are use cases that require lower device complexity and reduced energy consumption compared what can be provided by NR Release 15/16 and which, at the same time, has higher requirements in terms of data rates and latency compared to what can be provided with LTE-MTC and NB-IoT. To address such use cases, 3GPP has initiated Release-17 activities on reduced capability NR devices (sometimes referred to as NR Light) [20]. The work will initially be carried out as a study item to be concluded at RAN #90e (December 2020), with an expected work item to follow.

The aim is to achieve the reduced device complexity and energy consumption without compromising the achievable coverage. This Release-17 technology capability is not intended to replace mMTC low-power wide-area devices (i.e. eMTC/NB-IoT devices), but to enhance NR to address the following use cases in Industrial IoT and other verticals:

- **Industrial wireless sensors with 99.99% availability, latency less than 100ms in general and 5-10ms for safety-related sensors, and medium data rate (<2 Mbps), and battery life of a few years.**
- **Video transmission with 99%-99.9% reliability, latency less than 500ms, and medium to high data rate (2-25 Mbps).**
- **Wearables with high data rate (up to 150**

Mbps for downlink and up to 50 Mbps for uplink) with long battery life (up to 1-2 weeks).

These use cases have higher requirements than mMTC but lower than eMBB and URLLC. The objective is to first study and identify solutions for:

- **Reducing UE complexity, for example, by means of reduced number of Tx/Rx antennas, reduced UE bandwidth, half-duplex operation (no simultaneous Tx/Rx) in paired spectrum, relaxed device processing time and relaxed device processing capability.**
- **Mitigating impact from UE complexity reduction, for example, coverage compensation**
- **UE power saving and battery life enhancements, for example, by means of extended DRX, reduced complexity in control-channel monitoring and, RRC relaxation for stationary devices.**
- **Definition of reduced-capability devices and ensuring they are only used for the intended use cases.**
- **Device identification by the network and access restriction.**

Reduced capability devices should be supported in all FR1 and FR2 bands, and the design should also support a compact device form factor.

3.2.3.4 Small-Data Enhancements

NR Release 15/16 does not allow for the transmission of user data in inactive state (RRC_INACTIVE). As a consequence, even for the transmission of very small amount of data the device has to resume the connection (enter

RRC_CONNECTED state), something that has a negative impact on signaling overhead as well as device energy consumption. For this reason, Release 17 will introduce the possibility for transmission of small data payloads, in both the uplink and downlink directions, also in inactive state [21]. For uplink transmissions, this will be partly based on the already existing mechanisms of 2/4-step RACH (Section 3.2.2.12), including an extension of the maximum payload size supported.

In addition, the work item aims at enabling uplink small-data transmission using configured PUSCH resources, based on the Release-15/16 configured-grant framework, also in inactive state.

The use of small data transmission is configured by the network, including the configuration of data-volume threshold based on which a device determines whether to use small data transmission or to request a transition to active state for the uplink data transmission.

3.2.3.5 Sidelink Enhancements

As described above (Section 3.2.2.9), the Release-16 work item on NR V2X introduced the possibility for sidelink (direct device-to-device) communication in NR. Although focusing on the V2X scenario, the Release 16 sidelink can also be used for, for example, public safety.

Further enhancements and extensions to NR sidelink communication will be introduced as part of Release 17 [22]. The aim of these enhancements/extensions is to:

- **Enhance sidelink communication for V2X and public safety use cases in order to support requirements and operation scenarios not fully covered by Release-16 sidelink**
- **Extend sidelink communication to new commercial use cases**

The scope of the enhancements includes reduced device energy consumption during sidelink operation and enhanced reliability and reduced latency for sidelink communication for URLLC-type applications.

In parallel to the work item on sidelink enhancements as outlined above, 3GPP will also carry out studies on sidelink-based relaying, that is, the use of device-to-device communication as a way to extend the network coverage outside the area directly covered by the network infrastructure [23].

3.2.3.6 Positioning enhancements

The native positioning support introduced in NR Release 16 (section 3.2.2.11) targeted both regulatory and commercial use cases with positioning accuracy down to at least 3 meters and end-to-end latency less than 1 second as the performance target for commercial use cases.

A Release-17 study item on enhanced positioning [24] focuses on more high-accuracy positioning (both horizontal and vertical) targeting commercial IoT use cases such as location of assets and moving objects within factories, with sub-meter-lever accuracy (less than 1m for general commercial use cases and less than 0.2m for IIoT use cases) and end-to-end latency less than 100 ms in general and around 10ms for some IIoT use cases.

The aim of the study item is to study enhancements to support high-accuracy and low latency positioning in both horizontal and vertical domains, including

1. Evaluate the achievable accuracy and latency with the Release 16 positioning features and identify any performance gap.
2. If needed, identify and evaluate enhanced positioning techniques that can be used to reach the targets for high-accuracy positioning as outlined above. Enhancements to Release 16 positioning techniques will be prioritized over new techniques.
3. Identify solutions to support integrity and reliability of position information and positioning assistance information.

3.2.3.7 Dynamic spectrum sharing

The Release-17 work item on dynamic spectrum sharing (DSS) focuses on further enhancements in terms of spectrum sharing between NR and LTE [25]. Currently, the scheduling capability of an NR carrier that operates in DSS with LTE may be limited by the fact that the NR carrier is limited to a one symbol PDCCH control channel. The reason is that, in case of NR operation is spectrum shared with LTE, the first two symbols of the NR slot is occupied by LTE CRC.

To address this limitation, the release-17 DSS work item will extend the possibilities for cross-carrier scheduling (separate carriers for PDCCH carrying scheduling assignment/grant and the actual downlink/uplink data transmission on PDSCH/PUSCH) to also support PDCCH on SCell scheduling PDSCH/PUSCH on Pcell / PSCell. This will extend the possibilities for scheduling data transmission on an NR carrier

operating in DSS with LTE as the scheduling assignments/grants can be carried on a different NR carrier not operating in DSS and are thus not subject to the same PDCCH capacity limitation.

The work item will also consider introducing the possibility to schedule PDSCH on two carriers in parallel using a single DCI, further extending the scheduling efficiency.

3.2.3.8 MIMO enhancements

As described above (Section 3.2.2.1), Release 16 included a set of new features to enhance NR MIMO operation, for example, in terms of multi-beam operation and multi-TRP transmission. Additional MIMO enhancements in this area are introduced as part of NR Release 17 [26]. For example, this includes enhancements within the following areas/scenarios:

- **Enhanced multi-beam operation in high-speed vehicular scenarios, especially at higher frequencies, where further reduction in overhead and latency as well as a reduction in beam failure is desired.**
- **Extension of multi-TRP transmission, in Release 16 only applicable to the downlink PDSCH physical data channel, also for the uplink transmission direction as well as to the downlink PDCCH control channel. Multi-TRP transmission will also be extended to transmission points of different cells, that is, TRPs associated with different Physical Cell Identities (PCIs).**
- **Enhancements to SRS (Sounding Reference Signal) transmissions, for example, to extend capacity and coverage.**

- **Further enhanced Type II CSI-RS, for example, to enable multi-TRP/panel transmission in case of non-coherent joint transmission and utilization of partial reciprocity (for example reciprocity in terms of angle-of arrival/departure and delay) in case of FDD deployments.**

3.2.3.9 UE power saving enhancements

As described in Section 3.2.2.4, means for reduced NR UE energy consumption for devices in connected state were introduced already as part of NR Release 16. Release 17 will consider additional UE power saving features specifically targeting devices in idle/inactive mode [27]. This will include means to reduce unnecessary UE paging receptions and means to make TRS/CSI-RS occasions currently available only for connected state available also to devices in idle/inactive state.

Release 17 will also consider extensions to the Release-16 UE PDCCH-based power-saving adaptation including PDCCH monitoring reduction when C-DRX is configured.

3.2.3.10 Non-terrestrial network

During Release 15 and Release 16, 3GPP studied the feasibility and standard adaptations needed to enable NR communication over satellite systems referred to as Non-terrestrial Networks (NTN) [28]. For Release 17, a work item will be carried out along the lines of the preceding studies. The focus will be on transparent (non-regenerative) payload satellite systems for both Low Earth Orbit (LEO) and Geostationary Orbit (GEO) scenarios, with implicit support for high altitude platform station and air-to-group scenarios [29]. The NTN work item assumes FDD system, earth fixed tracking area, and UEs with GNSS capability.

Key technical areas include:

- **Means to handle the very large propagation delay, large Doppler effects, and moving cells, including:**
 - » *Timing-relationship enhancements*
 - » *Uplink time and synchronization enhancements*
 - » *HARQ operation, e.g. maximum number of HARQ process, enabling/disabling of HARQ feedback*
 - » *Random-access procedure, e.g. random-access response window, contention-resolution time, adaptation for Msg3 scheduling*
 - » *Enhancement on uplink scheduling to reduce latency*
 - » *Extension of the value range and sequence number space for RLC and PDCP parameters*
- **Control plane procedure enhancements, including**
 - » *Additional assistance information for cell selection/reselection e.g. satellite ephemeris information*
 - » *Handover enhancements considering location information of both devices and satellites*
 - » *Measurement enhancements to address propagation delay difference between satellites*
 - » *Service continuity for mobility when moving between terrestrial and non-terrestrial networks*
- **NG-RAN architecture enhancements to support feeder link switch over**

3.2.3.11 NR Broadcast/Multicast

Broadcast/Multicast (BC/MC) functionality for NR will be introduced in Release 17 [30]. Some of the intended use cases are Public Safety, V2X applications, IP4/IP6 multicast delivery, IPTV, software delivery over wireless, group communications and IoT applications.

The work item objectives include:

- **For devices in connected state, specify the following functions:**
 - » *Group-scheduling mechanisms for broadcast/multicast service, including support for simultaneous reception of broadcast/multicast and unicast services by the devices*
 - » *Dynamic change of broadcast/multicast service delivery between multicast and unicast transmission with service continuity*
 - » *Basic mobility with service continuity*
 - » *Means for improved reliability of broadcast/multicast services, e.g. via uplink feedback*
 - » *Dynamic control of the broadcast/multicast transmission area within one gNB*
- **For devices in idle/inactive state, specify functions that will allow the devices to receive broadcast/multicast service. Aim to minimize the differences in the reception of broadcast/multicast service between devices in connected state and idle/inactive state.**

3.2.3.12 Multi-Radio Dual Connectivity enhancements

The Release-17 work item on multi-radio dual-connectivity (MR-DC) enhancements builds on the corresponding MR-DC enhancements of Release 16 (Section 3.2.2.6) and the Release-16 mobility enhancements (Section 3.2.2.5).

As discussed in Section 3.2.2.5, Release 16 introduced the concept of conditional handover where a device is preconfigured with handover commands with the actual handover then triggered by, for example, the channel conditions to the current cell falling below a certain threshold. However, the Release-16 conditional handover only applies to the PCell, i.e. handover of the primary cell of the Master Cell Group (MSG). Release 17 aims to extend the conditional handover to also cover the case of conditional PSCell change, that is, change of the primary cell of a Secondary Cell Group (SCG), as well as conditional PSCell addition. The purpose of these extensions is to speed up SCG change/addition procedures.

Furthermore, the work item aims to support more efficient activation/deactivation mechanisms of

- **One SCG for the case of NGEN-DC, that is dual connectivity between NR and LTE with MSG based on LTE and SCG based on NR, as well as for dual connectivity between two NR carriers**
- **One SCell for the case of NR dual connectivity.**

The main idea is to save UE energy by deactivating the SCG between data bursts. This means that the UE will not monitor for

scheduling commands on the PSCell (the primary cell of the SCG). Consequently, a mechanism to quickly activate the SCG, for example by means of a MAC-control-element (MAC-CE) signaling needs to be introduced.

3.2.3.13 eXtended Reality (XR)

Applications relying on XR (eXtended Reality), as well as cloud-based gaming, are expected to continuously increase in importance. With this in mind and based on work carried out within various 3GPP/SA groups, see for example [36] and [35], 3GPP/RAN is carrying out a Release17 study item with the aim to evaluate current NR support for such applications. More specifically the object of the study item is to:

- **Identify XR and cloud-gaming applications of interest, based on XR applications identified in [36]**
- **Identify the, for an evaluation, relevant characteristics/requirements of such applications, including traffic characteristics and relevant performance and capability requirements**
- **Carry out the evaluations of the identified applications based on the identified characteristics and requirements**

Based on the study-item evaluations, conclusions can be drawn on to what extent, if any, further enhancements and extensions of NR radio-access are needed to fully support the expected future XR and cloud-gaming applications.

Already during the discussions leading up to the study item, some specific areas of relevance for the XR and/or cloud-gaming applications were identified.

Throughput

XR and cloud-gaming applications are typically associated with high throughput, often in combination with URLLC requirements, that is, requirements on very low latency and very high reliability. Furthermore, there will be relatively large short-term variations in the throughput, with the peak throughput of a device often several times higher than the average throughput over the session.

Mobility

XR and cloud-gaming applications are expected to be available also for users on the move, implying that mobility, and the possibility to retain user experience during mobility event, needs to be considered.

Device power

In general, the device power consumption is an important aspect for XR and cloud-game applications. Especially, if the XR experience is to be provided by means of small-form-factor AR glasses, there are more limitations on the power dissipation, especially if the AR glasses are to be worn for a prolonged time.

3.2.3.14 Support for Multi-SIM devices

Multi-SIM devices enable use of multiple subscriptions, potentially for different networks, in one device. As of today, multi-SIM devices are supported with no specific support within the 3GPP specifications. The Release-17 work item on Support for Multi-SIM Devices aims to introduce such support, thereby enabling enhanced performance and user experience in case of a multi-SIM device [31].

One objective of the work item is to address the issue of collision of paging messages from two different networks for multi-SIM devices. Another objective is to specify mechanisms that a multi-SM device can use to notify the current network when it, for some reason, switches to another network associated with a different SIM.

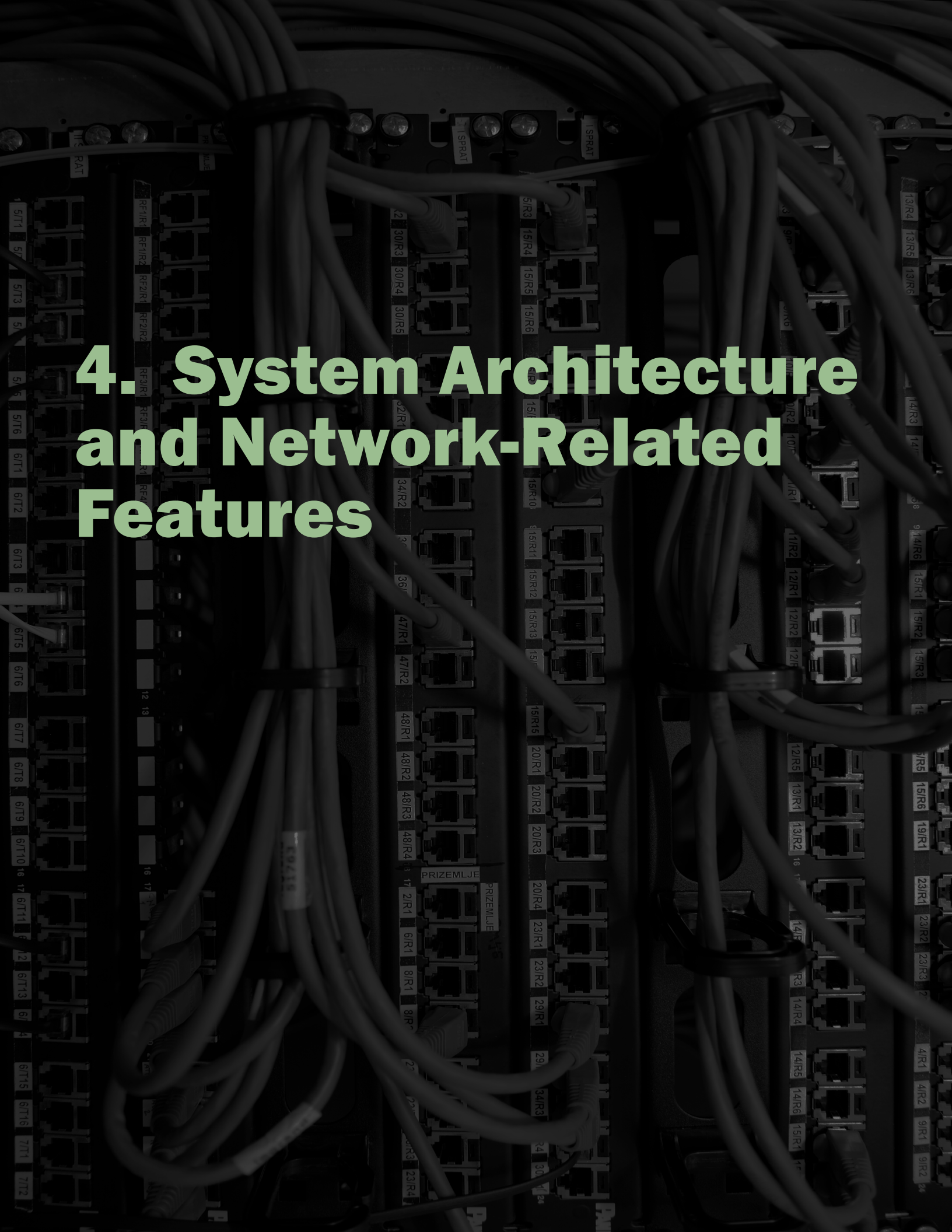

4. System Architecture and Network-Related Features

4. System Architecture and Network-Related Features

Upcoming 3GPP releases will also include enhancements and specifications relating mostly to 5G but also sometimes relating to LTE system architecture and network-related features. Areas of focus include 5G deployment options and migration, as well as newly introduced 5G radio access and core network key features.

4.1 5G Deployment Options and Migration

The 5G eco-system currently invests in and plans to roll out two variants of 5G (Figure 4.1), both initially based on 3GPP Release 15. Option 3 depicts Non-standalone (NSA) NR, also referred to as dual connectivity. Option 3 displays how NR boosts the throughput of a device connected to LTE/EPC (for example, 4G RAT and 4G Core). This is done using E-UTRAN - NR Dual Connectivity (EN-DC). The second variant of 5G to be rolled out is Standalone (SA) NR (Option 2), where the UE connects using only 5G technologies (NR and 5GC). The target architecture for the 5G migration is to use SA NR and 5GC as far as possible, even though LTE/EPC will need to remain for a long time to handle legacy devices.

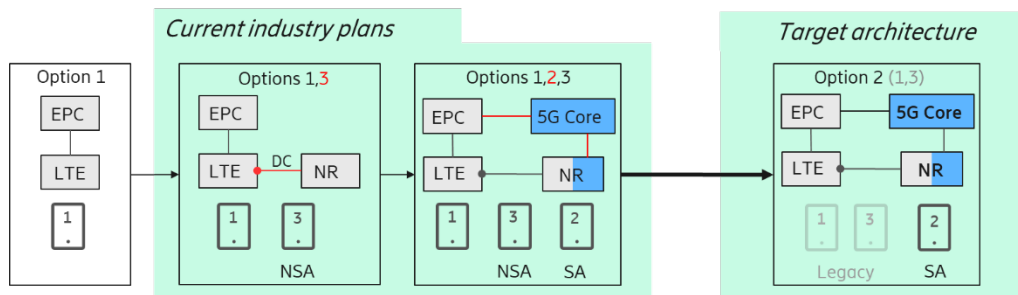

Fig. 4.1. Migration towards 5G target architecture.

We acknowledge that there are other Options defined in 3GPP, involving variants to upgrade LTE to 5G, but 5G Americas believes the benefit of focusing on the currently planned Options (3 and 2) will allow the industry to scale the 5G eco-system.

Figure 4.2 summarizes how to migrate to 5G using a combination of Options 1, 3, and 2, that is, LTE, NSA NR, and SA NR. The focus here is on wide-area services, where the area rollout of NR will expand gradually, both on new TDD spectrum (mmW or sub-6 GHz) and in lower bands (spectrum sharing). Figure 4.2 also illustrates a 5GC-capable device using different connectivity options depending on the current NR spectrum coverage. When NR is available with good coverage and wide bandwidth, SA NR Option 2 is used. Where NR is only available on partial spectrum, NSA NR Option 3 can be used. Outside NR coverage, plain LTE Option 1 is used.

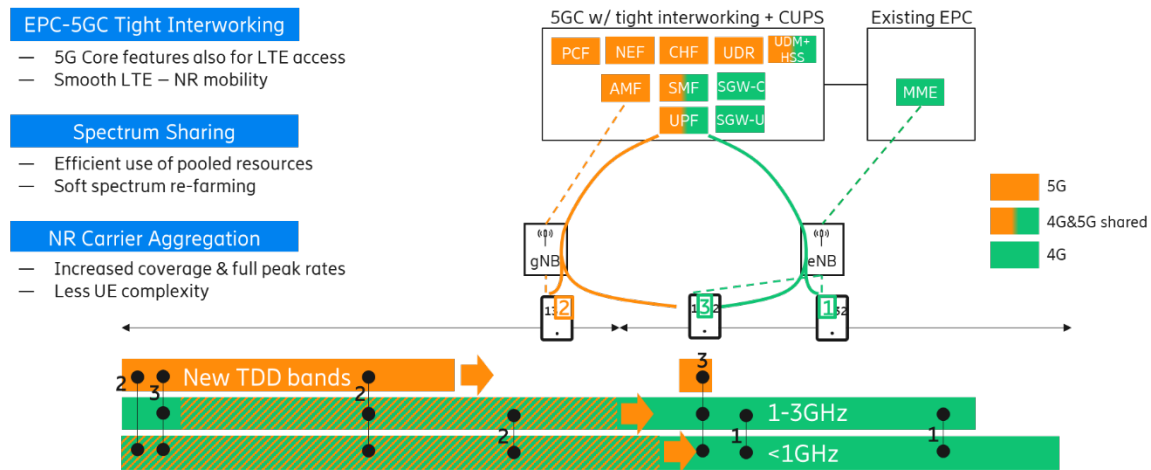

Fig. 4.2. Migration to 5G using Options 1, 3 and 2.

There are four key technology enablers for this migration to 5G:

1. EPC-5GC Tight Interworking

EPC-5GC Tight Interworking is used to handle areas with insufficient NR coverage during the 5G migration. It can be used with different deployment cases - illustrated in Figure 4.2 is a new 5GC with embedded EPC functions which interworks with an existing EPC that serves legacy LTE/EPC devices. This solution is based on 3GPP-specified EPC-5GC Tight Interworking and 3GPP-specified EPC CUPS (Control-User Plane Separation). In this way, a 5GC-connected device that moves out of NR (Option 2) coverage will be supported on LTE (Option 1 or Option 3) while still being anchored in the same 5GC gateway. Key 5GC features will be retained as well as smooth LTE-NR mobility. In terms of mobility, there are several handovers under NSA and SA scenarios to consider. For NSA (Option 3), possible handover (HO) scenarios are:

» **LTE mobility:**

- Inter-MCG HO with SCG release
- Inter-MCG HO without SCG release

» **NR mobility:**

- Inter-SCG HO with SN change

Note: Dual connectivity allows simultaneous connections with both technologies' LTE & 5G NR. eNB is part of the Master Cell Group (MCG) and gNB is part of the Secondary Cell Group (SCG). MCG and SCG are also referred to as master node (MN) and secondary node (SN), respectively.

For LTE HO with SCG release operation, due to dual connectivity, the user data continues over LTE radio bearer, even after SCG is released. For LTE HO when SCG is not released, an SN change during HO, may still be needed when source and target SNs are different.

For NR mobility, new NR measurements A3 and A5 are introduced. Similar to LTE, A3 is primarily used for intra-frequency and A5 for inter-frequency handover. NR measurement is determined an Intra-frequency when both SSB frequency and SCS are the same. If SSB frequency or SCS is different, it is considered an Inter-frequency measurement. gNB-to-gNB neighbor definitions and EN-DC relations are a pre-requisite for NR mobility in NSA.

For SA (Option 2), possible handover (HO) scenarios are:

- Intra-gNB HO
- Inter-gNB (Xn or NG) HO, Intra-AMF/Intra-User Plane Function (UPF)
- Inter-gNB (Xn or NG) HO, Intra-AMF/Inter-UPF
- Inter-gNB HO, Inter-AMF/Inter-UPF
- Inter-gNB HO, Inter-AMF/Intra-UPF
- Inter-RAT HO (between 5G SA and LTE)

where,

Intra-gNB HO is when both the source and target cells belong to the same gNB.

Inter-gNB HO is when both the source cell and target cell belong to different gNBs.

For Intra-AMF, AMF will not change as a consequence of the handover. In addition, the UPF may (intra-UPF) or may not (inter-UPF) be relocated. gNB interfaces with AMF via N2, with other gNBs via Xn or with eNBs via X2 can be used.

For Inter-AMF, in this case, the handover involves a change of AMF via signaling messages through the N14 interface between the source and target AMFs. In addition, the UPF may (intra-UPF) or may not (inter-UPF) be relocated. Inter-AMF HOs by default are N2 based Handovers.

For inter-RAT handover N26 interface is required between 5G Core (AMF) and LTE core (MME). Note: Inter-RAT Mobility is useful in early stages of SA deployment due to potential gaps in SA coverage (in CONNECTED mode using packet switched handover and in IDLE mode using RRC Release with Redirect).

2. Dynamic spectrum sharing

Dynamic spectrum sharing, as supported by Release 15, will enable quick NR deployment on existing LTE bands, with efficient pooling of the resources between LTE and NR. DSS provides a path for NR and LTE to co-exist while also enabling a granular spectrum re-farming. DSS preserves LTE frame structure and introduces NR on top of it by employing techniques to avoid collision between LTE and NR pilots. DSS leverages and reuses an LTE feature used for eMBMS called Multi-Broadcast Single Frequency Network (MBSFN). With MBSFN, LTE pilots (CRS-cell specific reference signal) can be removed and NR pilots (SSB – synchronization signal block) can be added. Data channels (LTE/ NR PDSCH) can be shared in both time and frequency. For time domain sharing certain slots are configured as MBSFN and NR data is scheduled at that instant. We can have a maximum of up to 60% of slots designated as MBSFN (best to start with lower number such as 20% and increase the MBSFN ratio based on its need).

The more universally adopted method for DSS is to use a Rel15 feature called CRS rate matching which lets NR UE know the presence of LTE pilots (CRS) and they work around these LTE signal. For this feature UE's need to support/advertise CRS rate matching capability. With this technique PRBs can be shared in both the time domain and frequency domain between LTE and NR. In UL, since we have fewer control channels, resources are shared mainly in frequency domain, and pilots from both RATs can co-exist with any additional requirements.

3. EN-DC, NR Carrier aggregation

EN-DC, NR Carrier aggregation and NR-DC are key motivators to deploy NR on lower FR1 bands, and to move to SA NR. Carrier aggregation provides best coverage performance, increased downlink usage of the new 5G TDD spectrum, best data rate aggregation performance and less UE complexity within sub-6-GHz bands compared to the dual transmitters needed for dual connectivity solutions.

EN-DC (E-UTRAN - NR Dual Connectivity) is a flavor of dual connectivity to combine 5G NR and 4G LTE. NR Carrier aggregation (CA) requires an uplink only on the Primary Cell (PCell), while EN-DC requires an uplink on both the master cell group (LTE) and secondary cell group (NR). In FR2 (millimeter wave), where the UL range can be quite limited, NR CA with uplink on FR1 can help extend the range of the mmW in downlink, while EN-DC cannot. EN-DC will slowly phase out with the introduction of SA and increased penetration of Option 2-capable devices.

Many FR1-FR2 NR CA combinations have been standardized. NR CA has advantages over DC with quicker aggregation response at the MAC layer (instead of the PDCP layer for DC) and with DL coverage extension described above.

Several FR1-FR2 NR-NR Dual Connectivity (NR-DC) combinations have been standardized as well. Like EN-DC, NR-DC requires an uplink on both FR1 and FR2; however, like NR CA it is an all-NR solution (Option 2) with both 5G core and RAN.

4. Voice over NR (VoNR)

Voice over NR (VoNR) is an essential enabler to 5G migration. When 5G core is deployed (Option 2), voice is leveraged using the 5G core functions and IMS, while the 5G data is delivered by the NR and the 5G core. Voice services are provided in one of two ways. The first is EPS Fallback, where a mobile phone will be forced to fall back from 5G to LTE during voice call set up. Voice and data traffic are carried over LTE for the duration of the call. This is the voice solution for initial deployments, and the only voice solution the first 5G SA handsets will support.

The second uses Voice over New Radio (VoNR), where voice is natively handled over the 5G radio, allowing simultaneous voice and high-speed 5G data. Network coverage is no longer restricted to LTE service areas as is the case in Option 3, however, LTE coverage will continue to be important due to the practical issue that 5G radio has shorter range due to its higher frequencies. Although VoNR is the long-term endpoint, mobile phones and networks are expected to support only EPS Fallback on initial deployment of Option 2.

Similarly, emergency calls will migrate from UE reselection to LTE (5GC not support Emergency Call) to EPS Fallback using service-request for emergency by the UE (NR and 5GC not need to support emergency features) to EPS Fallback using QoS triggered during call establishment (NR and 5GC need to support emergency features) and finally to a seamless mobility of Emergency over NR support between 5GC and EPS using IRAT handover.

4.2 5G RAN/CN Architecture and Key Features

The influence from vertical industries such as automotive, industrial IoT (e.g. factory automation), Cellular IoT, Transport and Satellite industry and Wireless/Wireline convergence will drive many of the new features development for 3GPP's next rounds of releases. Additionally, requirements on deployment flexibility and roaming improved overall architecture for better automation and virtualization are leading to improvements of the architecture.

4.2.1 5G RAN and CN Architecture and Key Features for Release 16

In Release 16, 3GPP has continued enriching the 5G system with new features like Ultra-reliable low latency architecture support, 5G LAN services, Time Sensitive Networking for Industrial IoT, Non-Public Networks, Integrated Access and Backhaul (gNB self-relaying), support of Data Connectivity (PDU Session) using simultaneously 3GPP and Non 3GPP Access, and cellular IoT support. In addition, Release 16 enhances the base architecture of Release 15 with features like enhancing the Service Based Architecture, improving flexible deployments of Session Management Control Function (SMF) and User Plane Function (UPF), support for commercial services using location based service architecture, enhancements to UE capability signaling, RAN Self-Organizing Networks, Dual Connectivity and Carrier Aggregation enhancements.

Some of the key features as identified by 3GPP SA2 and RAN work items are listed here, in no particular order:

Table 4-1. Key Features for Release 16.

Enhancement of URLLC supporting in 5G	5G_URLLC
5GS Enhanced support of Vertical and LAN services, Private Network Support for NG-RAN, and Support of NR Industrial Internet of Things (IoT)	Vertical LAN, NG_RAN_PRN, NR_IIoT
Cellular IoT support and evolution for the 5G System	5G_CIoT
Architecture enhancements for 3GPP support of advanced V2X services	eV2XARC
Enhancement to the 5GC Location Services	5G_eLCS
Optimizations on UE radio capability signaling	RACS
Study on architecture aspects for using satellite access in 5G	FS_5GSAT_ARCH, FS_NR_NTN_solutions
Enablers for Network Automation for 5G	eNA
Wireless and Wireline Convergence for the 5G system architecture	5WWC
Enhancing Topology of SMF and UPF in 5G Networks	ETSUN
Access Traffic Steering, Switch and Splitting support in the 5G system architecture	ATSSS
Enhancements to Service Based Architecture	5G_eSBA
Enhanced IMS for 5G	eIMS5G
User Data Interworking, Co-existence and Migration	UDICOM
Enhancements for Background Data Transfer	xBDT
System enhancements for Provision of Access to Restricted Local Operator Services by Unauthenticated UEs	PARLOS
Enhancement of Network Slicing	eNS
Architecture enhancements for the support of Integrated Access and Backhaul	IABARC, NR_IAB
(Self-Organizing Networks) and MDT (Minimization of Drive Tests) support for NR	NR_SON_MDT SON
LTE-NR & NR-NR Dual Connectivity and NR Carrier Aggregation enhancements	LTE_NR_DC_CA_enh
NR mobility enhancements	NR_Mob_enh

These key enhancements in 3GPP SA2 and RAN work items warrant further discussion. For instance, the study on integration of satellite access based on NR in 5G architecture continues beyond Release 16 and requires close cooperation between CN and RAN lead work in the same area.

The enhancements for Service Based Architecture (eSBA) in 5GC enables indirect communication and delegated discovery through a Service Communication Proxy (SCP). This allows flexible architecture and NF communication via the SCP. By defining NF Service Set and NF Set, the network functions and services defined can be deployed and selected modularly and provide redundancy for the NF services.

The enhancement of Location Services (LCS) uses Release-15 baseline architecture and then adds support for commercial for location services including in roaming cases. Some of the additional functions include: NEF enabled exposure of location (using services of GMLC and AMF/UDM (Cell Identity)), control plane positioning for both 3GPP and non-3GPP accesses, Location privacy subscription, temporary blocking of positioning consent from the UE or from Application Function, low powered devices optimized location reporting using CIoT operations for LTE and bulk or deferred location reporting operation.

The network slicing function is being further improved with interworking support with EPS to 5GS mobility. It introduces a new procedure for reallocation of AMF and V-SMF as part of topology enhancement work in Connected mode, and also by reallocation to a new AMF during Idle mode mobility. Another added feature known as Network Slice Specific Authentication and Authorization (NSSAA) enables separate authentication and authorization per Network Slice. The trigger of NSSAA is based on subscription information from UDM and operator policy and may be performed when UE indicates support for the feature.

Another feature provided is Radio Capabilities Signaling Optimization (RACS) via optimized OTA signaling of UE Radio capabilities by introducing mapping of RACS ID to UE Radio Capability in the network. A RACS ID uniquely maps to a set of UE Radio Capabilities and is fixed once established. Multiple UEs can share a common RACS ID, while mapping between RACS ID to UE Radio capabilities will be stored in the network as

a new NF UE (radio) Capability Management Function (UCMF), as well as cached in RAN nodes and AMF. Two types of RACS ID are standardized, Manufacturer allocated RACS ID and PLMN allocated RACS ID where a PLMN may support either type - or both types.

Enablers for Network Automation (eNA), compared to Release 15 (that defined only an embryo of the feature), add data collection and network analytics exposure features. Different Analytics are specified and depending on the Analytics ID(s) requested by a consumer NF, the Network Data Analytics Function (NWDAF) has to collect specific data from one or multiple data sources. The Analytics ID also defines the output analytics information based on statistics or prediction from the data collected. Some examples of Analytics ID include: Slice Load Level information, Network Performance Information, UE Mobility Information, QoS sustainability, etc. A network may deploy multiple NWDAFs, whereby the capability of an NWDAF to provide certain Analytics ID(s) is available either via NRF or via local configuration.

Topology enhancement for flexible deployment of SMFs and UPFs (ETSUN) supports deployments where a SMF cannot control UPFs in the whole PLMN (examples include mobility between regions within a PLMN, inter-PLMN mobility and Corporate UPF access). The feature introduces an Intermediate SMF (I-SMF) entity, with I-SMF supporting selection and control of Intermediate UPF and selection of other UPF with breakout function. ETSUN also defines enhancements to better support deployments where a UPF is controlled by multiple SMFs by supporting the UPF capability to allocate the UE IP address.

In Release 16, 3GPP took some additional steps to enhance IMS and 5GC for the 5G architecture to better support IMS. These include: P-CSCF registration for discovery via NRF, SMF discovery of P-CSCF via NRF, providing SBA services via HSS for Cx and Sh, HSS registration in NRF, discovery of HSS instances and their capabilities (legacy vs SBA) to handle gradual migration and co-existence of Rx and N5 for policy and charging control (PCC). In addition, an enhancement was introduced to support **Single Radio Voice Call Continuity (SRVCC) from 5G IMS to 3G**.

Release 16 provides architectural enhancement in the form of a new Service Based Interface for interaction between HSS and UDM for user data interworking, migration and co-existence between EPS and 5GS. In addition, a 3GPP 9x series technical report provides additional deployment options for the operators for the co-existence and migration without any changes to the 3GPP standards themselves.

5G_CIoT introduces support for ClIoT (similar to EPS) in 5GS for NB-IoT and LTE-MTC devices with 5GS support. The following features are included: Support for infrequent small data transmission (DoNAS), Frequent small data communication (UP optimization), High latency communication, Power saving functions, Management of Enhanced Coverage, Support of common north-bound APIs for EPC-5GC interworking, Monitoring, Network parameter configuration API via NEF, Overload Control for small data, Inter-RAT mobility support to/from NB-IoT, Support for Expected UE behavior, QoS Support for NB-IoT, Core Network selection for Cellular IoT, Group communication and messaging, Support of the Reliable Data Service and MSISDN-less MO SMS.

Vertical LAN and services for 5GS require several enhancements and additions to the architecture. Within this work area, three key components were addressed: 5G LAN services (5G_LAN), Time Sensitive Networking (TSN) and Non-Public Networks (NPN).

5G_LAN services provide group management services enabling 3rd parties (AF) to create, update and remove groups (may also be done via operator's O&M), including handling of 5G Virtual Network (VN) configuration data in the network and configuration of group member's UE. For 5G LAN session management, the feature optimizes support for communication within a 5G VN group with enablement of UE-to-UE communication.

3GPP Release 16 introduces Non-Public Network (NPN) support that enables the 5G architecture to deliver two types of NPN deployments: Stand-Alone Non-Public Networks – SNPN, and Public Network Integrated NPN – PNI NPN. The architecture also provides support for service continuity and support access of NPN services via PLMN and vice versa. SNPN provides the ability to offer connectivity only to authorized subscribers and prevent access to unauthorized UE(s) thereby also saving radio resources. The combination of a PLMN ID and Network identifier (NID) identifies an SNPN. The PLMN ID used for SNPNS is not required to be unique. PLMN IDs reserved for use by private networks can be used for non-public networks, e.g. based on mobile country code (MCC) 999 as assigned by ITU. Alternatively, a PLMN operator can use its own PLMN IDs for SNPN(s) along with NID(s), but registration in a PLMN and mobility between a PLMN and an SNPN are not

supported using an SNPN subscription given that the SNPNS are not relying on network functions provided by the PLMN.

The NID supports two assignment models:

- **Self-assignment: NIDs are chosen individually by SNPNS at deployment time (and may therefore not be unique) but use a different numbering space than the coordinated assignment NIDs as defined in [37].**
- **Coordinated assignment: NIDs are assigned using one of the following two options:**
 - » *The NID is assigned such that it is globally unique independent of the PLMN ID used; or*
 - » *The NID is assigned such that the combination of the NID and the PLMN ID is globally unique.*

The legal entities that manage the number space are beyond the scope of 3GPP specification.

PNI NPN operation is defined using the concept referred to as Closed Access Group (CAG) which enables the control of UEs' access to PNI NPN on a per cell basis (CAG cells). A UE may be configured with CAG information on a per PLMN basis.

Further enhancements to support NPNs are studied for subsequent releases including enabling support for UE onboarding and provisioning for an NPN, enabling support for SNPN along with subscription/credentials owned by an entity separate from the SNPN.

Time Sensitive Networking (TSN)

architecture enables 5GS to provide time synchronized and time bound packet delivery in the TSN bridge, to support industrial control using 5GS. For Release 16, the 5G System is integrated with an IEEE TSN network by acting as a TSN bridge. In Release-16, 5GS supports integration with IEEE TSN network based on a centralized TSN model configuration. Features that are supported include: deterministic services support, hold and forward buffer, TSC assistance information for optimized scheduling of deterministic traffic, 5GS logical TSN bridge management.

The entire 5G system can be considered as an 802.1AS "time-aware system". Only the network elements at the edges of the 5G system (translator/adaptor) need to support the IEEE 802.1AS operations.

5G URLLC architecture enhancements were done in the 5G system for redundant transmission support to enable better reliability for services that require URLLC communications support. Three different variants of solutions are available in Release 16. Operators can choose any or multiple mechanisms depending on the deployment and applications requiring URLLC services.

These variants are: dual connectivity based end-to-end redundant PDU sessions for the service associated with URLLC profile; redundant user planes between NG-RAN and UPF (redundant N3/N9 interfaces) for the same PDU session where only that link is considered need to be redundant; underlying transport network redundancy where UPF transmits packets utilizing two different redundant transport link and NG-RAN

eliminates redundant packets and vice versa. This requires redundant packet handling in UPF and NG-RAN. Additional enhancements have been made to improve handover performance and URLLC QoS monitoring features were introduced to react to any performance degradation. One method uses QoS flow end-to-end monitoring and the other uses existing GTP-U path monitoring function in the gNB and UPF(s) and allows to build a map of the delays between the different User plane entities (RAN and UPF) of the network. In addition, QoS can be monitored over Uu combined with GTP-U path monitoring function offers end to end QoS monitoring solution.

Enhanced V2X architecture developed an end-to-end architecture for delivering V2X services using either network connectivity (Uu interface) or sidelink (direct UE-UE) communication between the UEs using PC5 interface or a combination of both. The core network for 5G enables UE configuration via PCF (UE policy configuration capabilities in 5GS) as well as via V2X AF for both NR and LTE access. The key enhancements in NR compared to LTE PC5 include enhanced support of PC5 QoS aligned with QoS over Uu interface and support for three modes of PC5 operation, unicast, groupcast and broadcast. PC5 NR support is applicable to both stand-alone (5GS) and non-stand-alone (EPS with NR as secondary node). Using Network Analytics, QoS prediction statistical information is provided to V2X AF via NWDAF. Enhancement of Uu QoS with alternative QoS profiles for RAN allows to notify the Application with network conditions for a GBR flow (this function is not limited to V2X only). A V2X dedicated slice may be used in roaming environments and could be beneficial for OEMs. Specific 5QIs for V2X services has been defined as well.

Access Traffic Steering, Switch and Splitting support in the 5G system architecture (ATSSS) defines Multi-access PDU Sessions, i.e., PDU Sessions with simultaneous user-plane “legs” in 3GPP and non-3GPP access; this includes:

- **Access Traffic Steering: Selects an access network for a new data flow**
- **Access Traffic Switching: Moves all traffic of a data flow from one access network to another access network (“per-flow scheduling”)**
- **Access Traffic Splitting: Splits the traffic of a single data flow across multiple access networks (“per-packet scheduling”).**

Key concepts supported in Release 16 include the following:

- **Multi-access (MA) PDU Session is a PDU Session which can use simultaneous 3GPP and non-3GPP access for providing connectivity;**
- **Delegated user plane decisions:**
 - » *PCF provides ATSSS policy to SMF, and SMF provides corresponding rules to UE and UPF*
 - » *Uplink steering/switching/splitting decided by UE, based on ATSSS rules received from the SMF*
 - » *Downlink steering/switching/splitting decided by UPF, based on N4 rules received from SMF.*
 - » *Following steering modes are defined: Active-Standby, Smallest Delay, Load Balancing, Priority-based.*

- **Two steering functions (aggregation methods) supported:**
 - » *Multi-path TCP (MPTCP), for TCP traffic, with MP-TCP proxy functionality in UPF;*
 - » *Lower Layer (ATSSS-LL) function below IP, which is applicable to any traffic (TCP, UDP, IP, Ethernet).*
- **Basic measurements between UE and UPF to assist access selection**
 - » *UE reports access availability/unavailability to UPF (mandatory)*
 - » *UE and UPF may make RTT measurements per access (optional);*

ATSSS is currently not supported when moving from 5GC to EPC, except for the specific case of wireline access integrated to EPC/5GC with 5G-RG; ATSSS with one User Plane leg over E-UTRA connected to EPC and one over wireline access connected to 5GC is supported.

By collaborating with Broadband Forum (BBF) for convergence of wireline access using 5GS, 3GPP has developed the integrated architecture enabling wireline access connectivity towards 5GC via 3GPP interfaces and protocols (5WWC). The connectivity options include 5G-RG (RG enhanced with 5G capabilities) connecting via wireline access, 5G-RG using 3GPP access (Fixed Wireless Access FWA), 5G-RG using both wireline access and 3GPP access (Hybrid access) and legacy RG (FN-RG) using wireline access.

The Integrated Access and Backhaul (IAB) feature adds support for wireless backhauling of base stations using the NR radio interface (see also sections 3.2.2.2 and 3.2.3.2). It is an enabler for network densification without requiring fiber implementation in every base

station. The solution is designed to allow flexible deployment of NR base stations (called IAB nodes) utilizing the larger bandwidth on higher frequencies bands for wireless backhaul. The architecture is based on the gNB split architecture where the gNB-DU (Distributed Unit terminating the lower layers of the radio stack towards the UE) functionality is terminated in the (remote) IAB node, while the gNB-CU (Central Unit) functionality is terminated in a donor node. The IAB node reuses existing procedures defined for the UE to connect to the donor node. The solution has minimum impacts to the core network.

The work in Release 16 on **Self-Organizing Networks and Minimization of Drive Tests** adds NR support the SON features specified in LTE, as well as some NR specific enhancements for instance related to NR RRC inactive state.

The work on **LTE-NR & NR-NR Dual Connectivity and NR Carrier Aggregation enhancements** in Release 16 adds improvements to various carrier aggregation and dual connectivity solutions within NR and between NR and LTE. For example, reducing the setup latency for UEs to enter dual connectivity or CA in order to fully utilize the available bandwidth.

Release 16 also included work in the RAN working groups to improve the NR mobility with new solutions to improve robustness and end user performance, such as reducing service interruptions at handover. One such solution included a mechanism for conditional handover, where the network can configure the UE with multiple handover candidates as well as the conditions for triggering handover

towards the candidates. This improves robustness since the UE can trigger handover by itself in case the link to the source cell would suddenly be blocked.

4.2.2 5G CN Architecture and Key Features for Release 17

Release-17 core-network-standard features will be built on Release 15 and Release 16 specifications. It will provide further system enhancements and some additional features that were not included in the previous releases. Current schedule for Release 17 was extended to mitigate for the pandemic-related travel restrictions and consequent fallback to electronic meetings. Release 17 study items should be completed in December 2020, and Release 17 complete (code freeze) date is scheduled for March 2022.

There are multiple studies and work items that are being proposed, approved, or progressing, in various stages and working groups in 3GPP as of this writing. This section will introduce some of these study or work items with some high-level descriptions. Effort is being made to highlight new important features with emphasis on architectural work (stage 2, SA2) but it is not a comprehensive overview of Release 17.

Some system enhancements and support for new services were added for Release 17. Example of the works involve asset tracking, audio-visual service production, Communication Service Requirements for Critical Medical Applications, 5G enhancement for UAVs (Unmanned Aerial Systems), service requirements on enhancements for cyber-physical control applications in vertical domains, multimedia priority services (phase 2), Support for Multi-USIM Devices, enhanced relays for energy efficiency and extensive coverage, and others. The details of these use case and requirements can be found in 3GPP SA1 working group's web links.

The 5G core network is designed to be modular with network slicing and Service Based Architecture, so multiple use cases can be supported. The system architecture working group (SA2) in Release 17 continues to develop system enhancements and new features to support existing and new use cases and requirements.

Table 4-2 shows the current list of Release-17 SA2 study/work items. Two noticeable features that are possible in Release 17 are multicast and broadcast capabilities for 5G and proximity services support for 5G. Both new features are essential in supporting mission critical services and other commercial services.

Table 4-2. List of work items in system architecture group for Release.

Acronym	Definition
5G_AIS	5G System Enhancement for Advanced Interactive Services
5G_ProSe	System enhancement for Proximity based Services in 5GS
5GSAT_ARCH	Integration of Satellite in 5G Systems
5MBS	Architectural enhancements for 5G multicast-broadcast services
eATSSS	Extended Access Traffic Steering, Switch and Splitting support in the 5G system architecture
eLCS_ph2	Enhancement to the 5GC Location Services-Phase 2
eNA_Ph2	Enablers for Network Automation for 5G - phase 2
enh_EC	enhancement of support for Edge Computing in 5GC
eNPN	enhanced support of Non-Public Networks
eNS_Ph2	Enhancement of Network Slicing Phase 2
eV2XARC_Ph2	Architecture enhancements for 3GPP support of advanced V2X services - Phase 2
ID-UAS	Supporting Unmanned Aerial Systems Connectivity, Identification, and Tracking
IIoT	Enhanced support of Industrial IoT - TSC/URLLC enhancements
MPS2	Multimedia Priority Service (MPS) Phase 2
MUSIM	Support for Multi-USIM Devices

SA2 Release-17 study on [architectural enhancements for 5G multicast-broadcast services \(5MBS\)](#): Multicast and broadcast features were defined for LTE but the services using those standards have not been widely deployed. However, this feature is important for multiple use cases in 5G such as CIoT, V2X, mission critical services, and others. In addition, with 5G Service Based Architecture, there is an opportunity to define a modular and simpler architecture. This study will be coordinated with corresponding RAN work. The goal for this study item is to define a framework for multicast and broadcast service.

SA2 Release-17 study on [System enhancement for Proximity based Services in 5GS](#): proximity services (also referred to as D2D direct communications) were also defined in LTE and is an important feature for public safety, V2X, and other commercial services for 5G services. This study will define a framework in coordination with the corresponding RAN work for supporting such features in 5G. There are two sets of objectives for this framework: one is to support public safety use cases, and the other is to support commercial use cases.

The [5G System Enhancement for Advanced Interactive Services \(5G_AIS\)](#) work item defines potential QoS parameters, e.g. new standardized 5QI(s), related to required latency for uplink transmission from UE to UPF plus downlink transmission from UPF to UE, required reliability for uplink sensor/pose data and downlink pre-rendered/rendered audio/visual data, and required high data rate in downlink direction related to KPIs such as FPS (frame-per-second) and resolution etc.

Integration of Satellite in 5G Systems

(5GSAT_ARCH) study has concluded on a set of reference satellite integration scenarios and architectural assumptions, i.e. satellite access scenarios, satellite and terrestrial access networks within a PLMN, PLMNs with shared satellite access, roaming and mobility between satellite only PLMN and terrestrial only PLMN, and satellite backhaul scenario. It also concluded on architectural assumptions for the reference architecture, including mobility management with large and moving satellite coverage areas, delay in satellite communication, QoS with satellite access, multi connectivity with full/hybrid satellite access, as well as regulatory aspects related to super-national satellite ground stations.

Extended Access Traffic Steering, Switch and Splitting support in the 5G system architecture (eATSSS) phase 2 is investigating aspects for UEs that can establish a MA PDU Session to 5GC over both 3GPP and non-3GPP accesses. The aspects covered in the study are the following: whether and how to support additional steering mode(s) or extensions of the existing steering modes, whether and how to support new steering functions, e.g. to allow splitting of UDP and Ethernet traffic (leveraging MPQUIC work being done at IETF), and whether and how to support multi-access PDU sessions with the 3GPP access leg connected to EPC and the non-3GPP access leg connected to 5GC.

For the **5GC Location Services (eLCS)** the work in 2020 was on essential Release-16 corrections.

Enablers for Network Automation for 5G (eNA) phase 2 is studying enhancements for

the Network Data Analytics Function (NWDAF) from both feature and architecture point of view. Several new use cases and key issues are described including enhancements to support logical decomposition of NWDAFs, interaction and coordination among multiple NWDAFs, efficient data collection to reduce the load on the NWDAF and the data sources, and considerations related to user consent when handling UE data. Several solutions described in this study also propose enhanced and new Analytics, like Session Management Congestion Control Experience, Redundant Transmission Experience, or Application server performance.

The study on **enhancement of support for Edge Computing in 5GC (enh_EC)** works on potential system enhancements to enhance the forwarding of some UE application traffic to applications/contents deployed in edge computing environment, including network based discovery of application servers, several improvements for seamless change of application server, exposure of network information between 5G System and the edge computing functions, support for I-SMF insertion or reselection based on application function (AF) request, etc.

The feature **enhanced support of Non-Public Networks (eNPN)** extends the support for Non-Public Networks in 5GS. The study item enhances the feature to cover additional stage 1 service requirements, i.e. support for Video, Imaging and Audio for Professional Applications (VIAPA) with simultaneous access to SNPN and PLMN, support of IMS voice and emergency services for Stand-alone Non-Public Network (SNPN), support of SNPNs with credentials owned by an entity (service provider) separate

from the serving SNPN thus enabling neutral host deployments, and also introducing enablers for onboarding UE(s) without subscription along with remote provisioning for SNPN and PNI-NPN.

Work on **Enhancement of Network Slicing (eNS) Phase 2** fills an identified gap in 3GPP specifications: it defines the support for the Generic Network Slice Template (GST) attributes defined by GSMA 5GJA. The proposed solutions are categorized into 7 key issues including supporting a network slice related quota on the maximum number of UEs and/or PDU sessions, limiting the data rate per network slice per UE, and allowing for dynamic adjustments to meet those limitations. Other solutions address constraints on simultaneous use of a network slice and supporting 5GC assisted cell selection to access a network slice.

Architecture enhancements for 3GPP support of advanced V2X services (eV2XARC) Phase 2 focuses exclusively on the development of mechanisms for power-saving operation of pedestrian UEs that are using V2X services, especially based on the technique of discontinuous reception (DRX). DRX has been introduced for communication over the Uu interface and Phase 2 of eV2XARC is considering its introduction for the PC5 interface, as well. It is currently being investigated if DRX operation is feasible and beneficial for PC5 at all and if yes, if it shall be controlled completely by the UE or based on core network assistance and coordination, if it shall be aligned with Uu DRX configurations, if it shall be activated and deactivated by the application layer, and more.

The technical report on **supporting Unmanned Aerial Systems Connectivity, Identification, and Tracking (ID-UAS)** studies mechanisms for Unmanned Aerial Vehicles (UAV) controller and UAV(s) identification and tracking in the 3GPP system, including how the 3GPP system can provide support for UAV to ground identification (e.g. to authorized third parties such as police devices), mechanisms to support UAV controller and UAV(s) authorization and authentication by UAV Traffic Management, and mechanisms to handle unauthorized UAVs and revocation of authorization that enables the system to keep track of and control UAV(s). Based on an incoming Liaison from the Aerial Connectivity Joint Activity (ACJA) it was agreed at SA2 that a networked UAV Controller is considered as a regular UE that is not subject to any aerial features or any additional authentication/authorizations.

The study on **enhanced support of Industrial IoT - TSC/URLLC enhancements (IIoT)** in the 5G System aims at enhancing support of IEEE Time Sensitive Network (TSN) and enhancements for Time Sensitive Communication (TSC) to support deterministic applications related to the following aspects: Uplink Time Sync with TSN GrandMaster (GM) being the device, support for PTP time sync for regular ETH and IP applications, UE to UE TSC communication with optimized routing, exposure of TSC QoS and Time Synchronization service enabling activation/deactivation, and introduction of “Use of Survival Time for Deterministic Applications in 5GS”.

Multimedia Priority Service (MPS) Phase 2 normative work focuses on support of data transport services and enhancements for MPS voice or vide calls over LTE and 5G.

With the growing usage of Multi-USIM devices in the market, the scope of the technical report on support for **Multi-USIM Devices (MUSIM)** is to study system enablers for better support of devices having two or more Universal-SIMs (USIM). The work focuses on handling of Mobile Terminated service with Multi-USIM device, enabling Paging Reception for Multi-USIM Device, and coordinated leaving for Multi-USIM device.

In addition to SA2 work, these are some other important works going on in other 3GPP working groups that provide complete system support and they also provide additional features that deem to be critical to the future 5G services. For example, CODEC working group (SA4)' 5GXR work to support AR/VR/XR applications.

5. Visions/Considerations on “Next Generation Wireless”



5. Visions/Considerations on “Next Generation Wireless”

The main focus of this white paper is on the technical content of 3GPP Release 16 and 17, that is, the most recently finalized 3GPP release and the release currently being specified respectively. As already described, Release 17 is currently anticipated to be finalized in the second quarter of 2022. However, the evolution of mobile communication technology will obviously not end with Release 17. Especially, the evolution of 5G will continue in subsequent releases, enhancing its capabilities and extending the use cases to which it can be applied. Furthermore, at some stage the wireless industry can be expected to transit from 5G into 6G, that is, Sixth Generation, mobile communication.

Most aspects of a future 6G wireless access technology are still open, including the question if 6G will correspond to a completely new air-interface technology or partly be based on a further evolution of currently existing technologies. At this stage, 6G-related activities are primarily focusing on identifying relevant future use cases that, in turn, will drive the requirements, in terms of capabilities, that need to be addressed by the future wireless-access solution. In parallel, research-related discussions are ongoing on basic technology that may be key components of a future 6G wireless-access technology.

A more detailed discussion of this future evolution of wireless access, including visions on future use cases and corresponding capability requirements to be supported, as well as a discussion on some specific technology components, are provided in the 5G Americas white paper Mobile Communication Beyond 2020 – 5G Evolution Towards Next G.

The paper also summarizes the various 6G activities currently ongoing or about to be started around the world. Below we summarize some of the key highlights of the 5G Americas white paper.

5.1 Use cases and corresponding capabilities

“Mobile Communication Beyond 2020 – 5G Evolution Towards Next G” outlines a variety of use cases deemed to be relevant for future wireless-access networks. Some of these use cases are partly supported already today or can be expected to be enabled by the more near-term evolution of 5G wireless access. Others are more futuristic and will serve as drivers for the long-term wireless access evolution including 6G. The use cases outlined in the white paper include:

- Extended reality (XR) including Virtual reality (VR), Augmented reality (AR) and Mixed reality
- Holographic communication, that is, the transmission of 3D holographic images from one/multiple sources to one/multiple end points in an interactive manner
- Digital twins, that is, the real-time representation of a physical entity within the digital domain
- Tactile/haptic communication, that is, the transmission of human tactile and haptic sensations, allowing for humans and machines to interact with their environment in real time.
- Medical/Health Verticals
- Massive- Scale IoT Networks
- Smart Agriculture and Livestock

These technology requirements below will drive the need for enhanced and extended capabilities for the future wireless access networks.

Extreme data rates

To serve the above use cases, the achievable data rates need to continue to be extended, where some use cases such as holographic communication and cyber-physical systems may require several 100 Gbps.

Extreme coverage

Although limited coverage may be sufficient for some use cases, many use cases rely on uniform coverage over large geographic areas. Eventually wireless connectivity should be available truly everywhere on earth including air and sea.

Extreme reliability

To fully satisfy the requirement of future advanced use cases such as robotic surgery and more advanced industrial remote-control applications require even further enhanced reliability and availability compared to current networks.

Extreme latency performance

Future networks should provide even lower latency than today. However, even more important may be the possibility to provide a predictable latency (very low delay jitter).

Precise location

To enable, for example, the advanced AR and VR use cases, future networks should enable extremely precision device location as well as being able to track objects in the vicinity of the user with high precision.

5.2 Some key technology components.

“Mobile Communication Beyond 2020 – 5G Evolution Towards Next G” also highlights some technology areas that are expected to provide key technology enablers for the future wireless access:

Artificial-intelligence-based automation

The emergence of massive use of artificial intelligence will clearly have a big impact on future wireless communication, in terms of driving the need for new and expanded capabilities of the network in order to be able to connect the expected vast number of intelligent machines. However, it will also serve as an important technology component within the networks themselves.

Artificial intelligence can be used at the network edge to reduce large amount of data collected, for example, from millions of low-rate IoT devices or high-rate video cameras, thereby lowering the requirements on the transport network connecting to servers at more central locations. AI at the network edge can also enable real-time AI responses, such as AI-based real-time face recognition.

However, AI will also be applied more deeply within the radio-access network, for example as a tool to enable/enhance/simplify network planning, radio resource management and even within the physical layer.

Extension to new higher frequency bands

One important part of the research activities for future wireless access is a further extension of the frequency bands being considered, including “sub-THz” frequency bands (100 GHz to 300 GHz) and even “THz” frequency bands (above 300 GHz).

The possible extension to sub-THz and even THz frequency bands can be seen as a continuation of the 5G extension into mmW bands, providing the possibility for even higher end user data rates and even higher network traffic capacity. It is important to note though that, similar to the 5G extension to mmW frequencies, such an extension to even higher frequencies will only be a complement, providing the opportunity for extreme traffic capacity and extreme data rates but only for very dense deployments. Lower frequency bands can be expected to be back bone for wide-area coverage of wireless connectivity also in the future.

Communication and sensing co-design

Communication and sensing co-design imply that the radio signals transmitted and received by infrastructure and/or devices are also, in parallel, used for sensing of the environments. This can range from the simple case of, for example, estimating the humidity of the air from the path loss experienced by radio transmission, to more radar-like functionality using transmitted and reflected radio waves to derive properties such as distance, posture, velocity and/or size of near-by objects. The latter will further benefit from an expansion into to higher frequency bands, enabling spatial-wise more accurate sensing due to the smaller wavelength. The benefit of combined communication and sensing is the reduced infrastructure expense, compared to deploying separate infrastructure for the sensing functionality. The sensing could further benefit from the billions of devices that will be present within the future wireless access networks.

A low-angle, upward-looking photograph of several modern skyscrapers with glass facades. The buildings are dark against a dark sky, creating a sense of height and scale. The perspective is from the ground looking up, with the buildings converging towards the top of the frame. The word "Conclusion" is overlaid in a bright green, bold, sans-serif font in the upper left quadrant.

Conclusion

Conclusion

2020 unwelcomed the Covid-19 Pandemic into the world. Yet, despite all of the global challenges during this historic year, 3GPP finalized Release 16 and initiated the work on Release 17.

In Release 16 the current 5G NR capabilities are enhanced from Release 15, improving the operational efficiency of the radio-access technology. In parallel, Release 16 has introduced new capabilities extending NR towards new verticals. Some key features of NR Release 16 are:

- **Support for Integrated Access Backhaul (IAB) extending NR to support also the wireless backhaul, thereby enabling, for example, rapid deployment of NR cells and new ways to provide NR coverage in areas with sparse fiber density**
- **Support for NR operation in unlicensed spectrum, both in form of license assisted access where an NR carrier in unlicensed spectrum complement and operates jointly with a carrier (NR or LTE) in licensed spectrum, and stand-alone operation**
- **Enhanced support for V2X, URLLC, and Industrial IoT, thereby extending/enhancing the applicability of NR to new usage scenarios including factory automation and transport industry**

Decisions by 3GPP were made on Release 17 in December of 2019 to improve network capacity, latency, coverage, power efficiency and mobility. In Release 17 in addition to general enhancements of current features, several new Release-17 features have been

outlined in this paper including:

- **Extending the operation of NR to spectrum above 52.6 GHz to 71 GHz**
- **Introducing Reduced Capability NR devices, that is, enabling services with a UE complexity/capability trade-off in between the conventional high-quality eMBB services and the low-complexity services enabled LTE-MTC and NB-IoT).**
- **Enhanced Dynamic Spectrum Sharing**
- **Multi-Sim devices**
- **More advanced Sidelink communications**
- **Small data capabilities**
- **Enabling broadcast/multicast services within NR**
- **Support for non-terrestrial networks (i.e. a satellite component of NR)**

For LTE, the extensions and enhancements in Release 16, and even more for Release 17, are more limited, reflecting the maturity of the LTE technology. A key focus for Release 16 has been further enhancements of the support for massive-MTC applications by means of enhancements to both LTE-MTC and NB-IoT, with further enhancements considered for Release 17. In parallel, Release 16 included LTE enhancements, for example, in terms of mobility and performance for high-speed scenarios such as very-high-speed trains.

Overall, the mobile wireless industry continues to make great strides in research, development, standardization and deployment of 5G technologies. The evolution and revolution in wireless continues with new standardized technical features at 3GPP as the mobile wireless industry connects more people and things in new markets.

Appendix

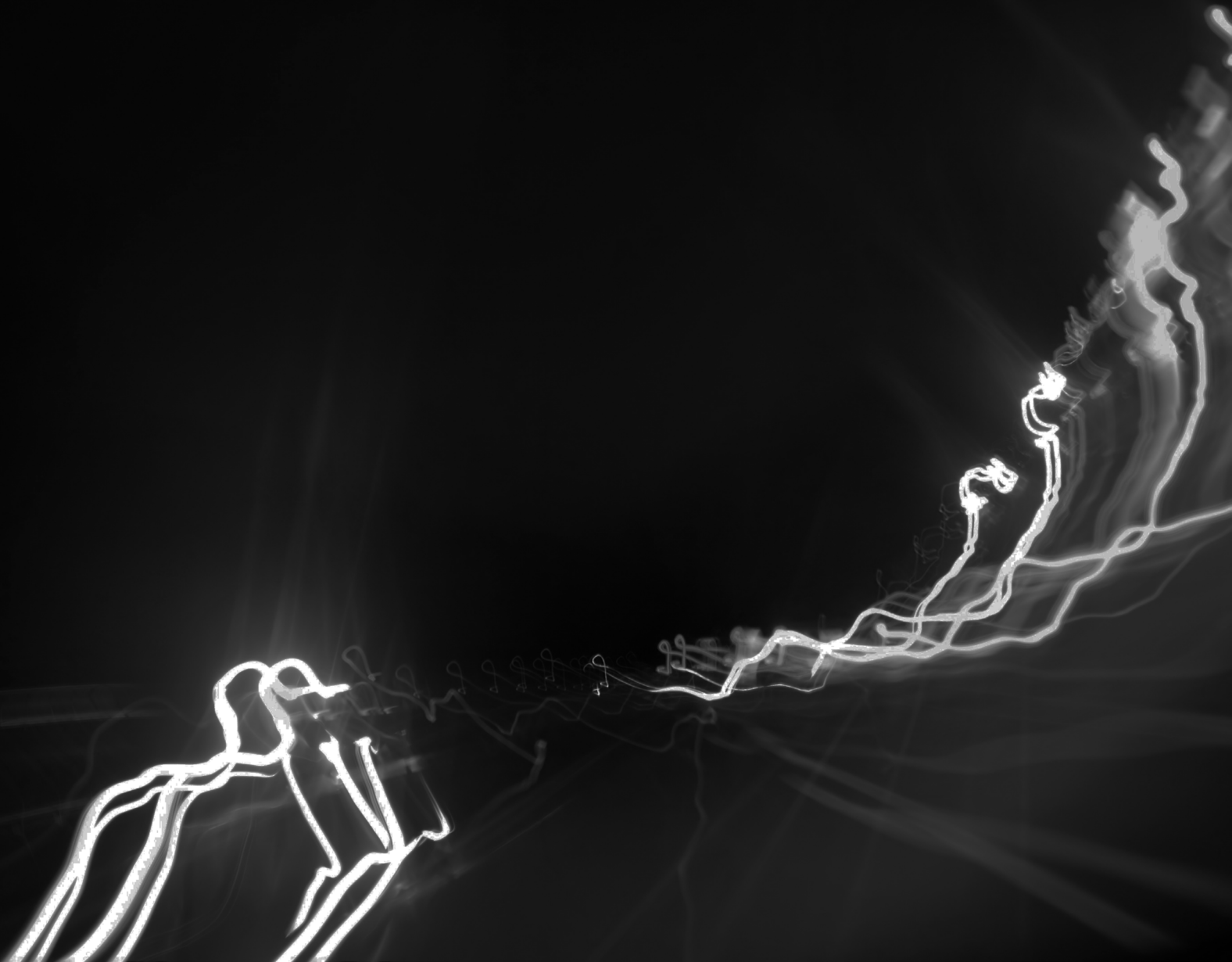

Appendix

Acronyms

3GPP	3rd Generation Partnership Project
4G	Fourth Generation
5G	Fifth Generation
5GC	Fifth Generation Core
6G	Sixth Generation
AI	Artificial Intelligence
AMF	Access and Mobility Management Function
AoA	Angle-of-Arrival
AoD	Angle-of-Departure
AR	Artificial Reality
BAP	Backhaul Adaptation Protocol
BC	BroadCast
BWP	Bandwidth Part
BF	Beamforming
CA	Carrier Aggregation
CAG	Closed Access Group
CAGR	Compound Annual Growth Rate
CAPEX	Capital Expenses
CIoT	Cellular IoT
CLI	Cross-Link Interference
cMTC	Critical Machine Type Communications
CN	Core Network
CoMP	Coordinated Multi-Point Transmission and Reception
CORESET	Control Resource set
CP	Control Plane / Cyclic Prefix
CQI	Channel Quality Indicator
C-RNTI	Cell RNTI
CS	Circuit Switched
CSI	Channel-State Information
CSI-RS	Channel-State Information Reference Symbol
CU	Control/ User Plane OR Central Unit
C-V2X	Cellular to Everything
DAPS	Dual Active Protocol Stack
D2D	Device-to-Device
DC	Dual Connectivity
DCI	Downlink Control Indicator
DL	Downlink
DL-RSTD	Downlink reference Signal Time Difference
DL-TDOA	Downlink Time Difference of Arrival
DMRS	Demodulation Reference Signal
DoNAS	Data over NAS

DRX	Discontinuous Reception
DSS	Dynamic Spectrum Sharing
DU	Distributed Unit
E2E	End-to-End
EB	Enhanced Beam forming
eMBB	Enhanced Mobile Broadband
eMBMS	Enhanced MBMS
eMTC	Enhanced MTC
EN-DC	E-UTRAN New Radio Dual Connectivity
eNodeB, eNB	Evolved Node B
EPC	Evolved Packet Core also known as System Architecture Evolution (SAE)
EPC/SAE	Evolved Packet Core/System Architecture Evolutions
ePDG	Evolved Packet Data Gateway
EPS	Evolved Packet System
ETSI	European Telecommunications Standards Institute
E-UTRA	Evolved Universal Terrestrial Radio Access
E-UTRAN	Evolved Universal Terrestrial Radio Access Network
FCC	Federal Communications Commission
FD	Frequency Division
FD	Full Dimension as in FD-MIMO
FDD	Frequency Division Duplex
FDM	Frequency-Division Multiplexing
FD-MIMO	Full-dimension MIMO
FR1	Frequency Range 1 (410 MHz – 7125 MHz)
FR2	Frequency Range 2 (24250 MHz – 52600 MHz)
FWA	Fixed Wireless Access
GEO	Geosynchronous (Satellite) Orbit
GERAN	GSM EDGE Radio Access Network
GMLC	Global Mobile Location Center
GNSS	Global Navigation Satellite System
GPRS	General Packet Radio Service
HARQ	Hybrid Automatic Repeat Request
HPHT	High-Power/High-Tower (broadcast scenario)
HSS	Home Subscriber Server
IAB	Integrated Access Backhaul
ID	Identity
IEEE	Institute of Electrical and Electronics Engineers
IIoT	Industrial Internet of Things
IMS	Internet Protocol Multimedia Subsystem
IMT	International Mobile Telecommunications
IoT	Internet of Things
IP	Internet Protocol
I-SMF	Intermediate SMF
ITU	International Telecommunications Union
LAA	License Assisted Access

LBT	Listen-Before-Talk
LCS	Location Services
LCM	Life Cycle Management
LEO	Low Earth (Satellite) Orbit (400 km to 2000 km)
LPE	LTE Positioning Protocol
LPWA	Low Power Wide Area
LTE	Long Term Evolution
MAC	Medium Access Control
MAC-CE	MAC Control Element
MBMS	Multimedia Broadcast Multicast Services
MBSFN	Multicast-Broadcast Single Frequency Networks
MC	MultiCast
MCG	MeNB Cell Group
MCS	Modulation and Coding Scheme
MDT	Minimization of Drive Tests
MEC	Multi-access Edge Computing
MEO	Medium-Earth (Satellite) Orbit (2000 km to just below geosynchronous orbit)
MIMO	Multiple-Input Multiple-Output
MME	Mobility Management Entity
mMTC	Massive Machine Type Communications
mmWave	Millimeter Wave
MPTCP	Multi-Path TCP
MPMT	Medium-Power/Medium-Tower (broadcast scenario)
MR-DC	Multi-Radio Dual Connectivity
MSISDN	Mobile Station International Subscriber Identity Number
MT	Mobile-Terminated (also used to indicate the north-bound part of an IAB node)
MTC	Machine Type Communications
MU-MIMO	Multi-User Multiple-Input Multiple-Output
NA	Network Automation
NB-IoT	Narrowband IoT
NE-DC	NR E-UTRA Dual Connectivity
NDI	New Data Indicator
NEF	Network Exposure Function
NF	Network Functionality
NG	Next Generation
NID	Network ID
NPN	Non-Public Network
NR	New Radio
NRF	Network Repository Function
NR-U	NR Unlicensed
NSA	Non-Standalone
NSSAA	Network Slice-Specific Authentication and Authorization
NTN	Non-Terrestrial Network

OCB	Occupied Channel Bandwidth
OFDM	Orthogonal Frequency Division Multiplexing
OPEX	Operating Expenses
OTA	Over-The-Air
OTDOA	Observed Time Difference of Arrival
PAPR	Peak-to-Average-Power Ratio
PCC	Policy and Charging Control
Pcell	Primary cell
PCI	Physical Cell Identity
P-CSCF	Proxy Call Session Control Function
PDCCH	Physical Downlink Control Channel
PDCP	Packet Data Convergence Protocol
PDSCH	Physical Downlink Shared Channel
PDU	Protocol Data Unit
PLMN	Public Land Mobile Network
PMCH	Physical Multicast Channel
PMI	Precoder Matrix Indicator
PNI NPN	Public Network Indicated NPN
PRACH	Physical Random Access Channel
ProSe	Proximity Services
PPP	Precise Point Positioning
PRS	Positioning Reference Point
PS	Packet Switched
PSD	Power Spatial Density
PSBCH	Physical Sidelink Broadcast Channel
PSCCH	Physical Sidelink Control Channel
PSFCH	Physical Feedback Control Channel
PScell	Primary Scell
PSSCH	Physical Sidelink Shared Channel
PTRS	Phase-Tracking Reference Signal
PUCCH	Physical Uplink Control Channel
PUSCH	Physical Uplink Shared Channel
QoS	Quality of Service
QZSS	Quasi-Zenith Satellite System
RACH	Random Access Channel
RACS	Radio Capabilities Signaling Optimization
RAN	Radio Access Network
RAR	Random Access Response
RAT	Radio Access Technology
RLC	Radio Link Control
RIM	Remote Interference Management
RIT	Radio Interface Technology (IMT-2020 proposal)
RMSI	Remaining Minimum System Information
RNTI	Radio Network Temporary Identity

ROHC	Robust Header Compression
RRC	Radio Resource Control
RRM	Radio Resource Management
RSRP	Reference Signal Received Power
RSRQ	Reference Signal Received Quality
RSSI	Received Signal Strength Indication
RSTD	Received Signal Time Difference
RTK	Real-Time Kinematic
RTOA	Relative Time of Arrival
RTT	Round-Trip Time
RV	Redundancy Version
Rx	Receive
SA	Stand-Alone
SBA	Service-Based Architecture
Scell	Secondary cell
SCI	Sidelink Control Indicator
SCG	SeNB Cell Group
SCG	Secondary Cell Group
SCP	Service Communication Proxy
SC-PTM	Single-Cell Point-to-Multipoint
SDM	Space Division Multiplexing
SFN	Single Frequency Network
SIM	Subscriber Identity Module
SINR	Signal-to-Interface-and-Noise Ratio
SL	Sidelink
SMF	Session Management Control Function
SNPN	Stand-Alone NPN
SON	Self-Optimizing or Self-Organizing Network
SRIT	Set of Radio Interface Technology(ies)
SRS	Sounding Reference Signal
SRVCC	Single Radio Voice Call Continuity
RX	Receive
TA	Time Alignment
TDD	Time-Division Duplex
TDM	Time-Division Multiplexing
TDOA	Time Difference Of Arrival
TRP	Transmission/Reception Point
TSC	Time Sensitive Communication
TTI	Transmit Time Travel
Tx	Transmit
UAV	Unmanned Ariel Vehicles
UC	UniCast
UCI	Uplink Control Indicator
UCMF	UE (radio) Capability Management Function
UDM	Unified Data Management

UE	User Equipment
UL	Uplink
UL-AoA	Uplink Angle-of-Arrival
UL-RTOA	Uplink Relative Time of Arrival
UL-RSRP	Uplink Reference Signal Received Power
UL-TDOA	Uplink Time Difference of Arrival
UPF	User Plane Function
URLLC	Ultra-Reliable Low Latency Communications
V2P	Vehicular-to-Pedestrian
V2V	Vehicular-to-Vehicular
V2X	Vehicle-to-Everything
VN	Virtual Network
VR	Virtual Reality
WG	(3GPP) Working Group
WI	Work Item
WID	Work Item Description
XR	Extended Reality

References

- [1] GSMA Intelligence, “Mobile World Congress Daily,” 2020.
- [2] 3GPP RP-191533, “Draft LTI on 3GPP final technology submission of 3GPP 5G solutions for IMT-2020”.
- [3] 3GPP RP-192875, “Additional MTC Enhancements for LTE (Work-item description)”.
- [4] 3GPP RP-200293, “Additional Enhancements for NB-IoT (Work-item description)”.
- [5] 3GPP RP-182901, “DL MIMO Efficiency Enhancements for LTE (Work-item description)”.
- [6] 3GPP RP-190921, “Even further Mobility Enhancements in E_UTRAN (Work-item description)”.
- [7] 3GPP RP-181482, “ Performance enhancements for high-speed scenario in LTE (Work-item description)”.
- [8] 3GPP RP-201306, “Rel-17 enhancements for NB-IoT and LTE-MTC (work-item description)”.
- [9] 3GPP RP-193235, “Study on NB-IoT/eMTC support for Non-Terrestrial Network (study-item description)”.
- [10] Formally, the core specification supports operation up to 52.6 GHz..
- [11] 3GPP RP-182863, “Enhancements on MIMO for NR (Work-item description)”.
- [12] 3GPP RP-190489, “NR Mobility Enhancements (Work-item description)”.
- [13] 3GPP RP-191608, “LT-NR & NR-NR Dual connectivity and CA Enhancements (Work-item description)”.
- [14] 3GPP RP-191561, “Support of NR Industrial Internet of Things (Work-item description)”.
- [15] 3GPP RP-191584, “Physical Layer Enhancements for NR Ultra-Reliable and Low-Latency Communication (URLLC) (Work-item description)”.
- [16] 3GPP RP-191156, “NR Positioning Support (Work-item description)”.
- [17] 3GPP RP-190711, “2-step RACH for NR (Work-item description)”.
- [18] 3GPP RP-200902, “Revised SID: Study on supporting NR from 52.6GHz to 71 GHz (study-item description)”.
- [19] 3GPP RP-193251, “New WID on Enhancements to Integrated Access and Backhaul (work-item description)”.
- [20] 3GPP RP-201677, “New SID on support of reduced-capability devices”.
- [21] RP-193252, “Work Item on NR small data transmission in INACTIVE state (work-item description)”.

- [22] 3GPP RP-133231, “New WID on NR sidelink enhancements (work-item description)”.
- [23] 3GPP RP-193253, “New SID: Study on NR sidelink relays (study-item description)”.
- [24] 3GPP RP-202094, “New SID on NR positioning Enhancements (study-item description)”.
- [25] 3GPP RP-193260, “New WID on NR Dynamic spectrum sharing (work-item description)”.
- [26] 3GPP RP-193133, “New WID: Further enhancements on MIMO for NR”.
- [27] 3GPP RP-193239, “New WID: UE Power Saving Enhancements (work-item description)”.
- [28] 3GPP TR 38.811, “Study on New Radio (NR) to support non-terrestrial networks”.
- [29] 3GPP RP-201256, “Solutions for NR to support non-terrestrial networks NTN (work-item description)”.
- [30] 3GPP RP-201038, “Revised work Item on NR support of Multicast and Broadcast Services work-item description”.
- [31] 3GPP RP-193250, “New WID: Support for Multi-SIM devices in Rel-17 (work-item description)”.

Additional References

- 3GPP, "Study on New Radio Access Technology: Radio Access Architectures and Interfaces. 3GPP Technical Specification," 3GPP, 2018.
- 3GPP, "TR 38.801, Technical Specifications Group Radio Access Network: Study on new radio access technology: Radio access architecture and interfaces," 3GPP, 2017.
- 3GPP, "TS 38.401, NG-RAN Architecture description," 3GPP, 2019.
- ITU-T, "Technical Report GSTR-TN5G - Transport network support of IMT-2020/5G," ITU-T, 2018.
- ITU-T, "Technical Report GSTR-TN5G, Transport network support of IMT-2020/5G," 2018.
- CPRI, "eCPRI Specification V2.0, "Common Public Radio Interface: eCPRI Interface Specification"," CPRI, 2019.
- G. Macri, "Deploying-5G-Will-Cost-at-Least-130-Billion-in-Fiber-Study-Says," 10 July 2017. [Online]. Available: <https://www.govtech.com/network/Deploying-5G-Will-Cost-at-Least-130-Billion-in-Fiber-Study-Says.html>.
- 3GPP, "RP-193251, Enhancements of Integrated Access and Backhaul," Dec 9 - 12, 2019.
- 3GPP, "Study on integrated access backhaul," 3GPP, 2019.
- 3GPP, "R1-1812199, System Performance Evaluation in Multi-Hop IAB network," Nov 2018.
- S.-Y. R. Li, R. W. Yeung and N. Cai, "Linear Network Coding," IEEE Transactions on Information Theory, vol. 49, no. 2, pp. 371-381, 2003.
- O. Orhan, H. Nikopour, J. Nam, N. Naderializadeh and S. Talwar, "A Power Efficient Fully Digital Beamforming Architecture for mmWave Communications," in 2019 IEEE 89th Vehicular Technology Conference (VTC2019-Spring), Kuala Lumpur, 2019.
- CableLabs, "Data-Over-Cable Service Interface Specifications - DOCSIS 1.0," CableLabs, 1997.
- CableLabs, "Low Latency Mobile Xhaul over DOCSIS Technology," CableLabs, 2019.
- CableLabs, "Low Latency Mobile Xhaul over DOCSIS Technology, CM-SP-LLX-I01-190628," CableLabs, Boulder, CO, 2019.
- J. Andreoli-Fang and J. T. Chapman, "Mobile-aware scheduling for low latency backhaul over DOCSIS," in Proc. of IEEE International Symposium on Personal Indoor and Mobile Radio Communications (PIMRC), Montreal, 2017.
- J. Andreoli-Fang and J. T. Chapman, "Latency reduction for mobile backhaul over DOCSIS through pipelining," in Proc. of IEEE Globecom, Singapore, 2017.

J. T. Chapman, J. Andreoli-Fang, M. Chavin, E. C. Reyes, L. Zheng, D. Liu, J. Padden and A. Bernstein, "Low latency techniques for mobile backhaul over DOCSIS," in Proc. of IEEE Wireless Communication and Networking Conference (WCNC), Barcelona, 2018.

CableLabs, "Synchronization Techniques for DOCSIS Technology Specification, Version I01," CableLabs, Boulder, 2020.

CableLabs, "Low Latency Mobile Xhaul over DOCSIS Technology," CableLabs, Louisville, 2019.

Bell Labs, "Quantifying the cost benefits of FTTH for 5G transport," Bell Labs, 16 April 2020. [Online]. Available: <https://www.nokia.com/blog/quantifying-cost-benefits-ftth-5g-transport/>. [Accessed 20 May 2020].

3GPP, "Study on scenarios and requirements for next generation access technologies," 3GPP, 2018.

IEEE, "IEEE P1914.1, IEEE Draft Standard for Packet-based Fronthaul Transport Networks," IEEE, 2019.

ITU-T, "G.8273.2 : Timing characteristics of telecom boundary clocks and telecom slave clocks," ITU-T, 2019.

IEEE, "1914.3-2018 IEEE Standard for Radio over Ethernet Encapsulations and Mappings," IEEE, 2018.

IEEE, "IEEE 802.1CM - Time-Sensitive Networking for Fronthaul," IEEE, 2018.

ABIresearch, "Mobile backhaul options -Spectrum analysis and recommendations," GSMA, 2018.

C. W. M. E. Jim Zou, "Optical fronthauling for 5G mobile: A perspective of passive metro WDM technology," in 2017 Optical Fiber Communication Conference and Exhibition (OFC), Los Angeles, CA, USA, 2017.

Commscope, "How WDM Helps With 5G Deployment," Commscope, 17 07 2017. [Online]. Available: <https://www.commscope.com/blog/2017/how-wdm-helps-with-5g-deployment/>. [Accessed 25 05 2020].

NGOF, "5G-Oriented OTN Technology," NGOF, 2018.

CableLabs, "P2PCO-SP-ARCH-I02-190311 - P2P Coherent Optics Architecture Specification," CableLabs, Louisville, CO, 2019.

ITU-R, "Recommendation M.2083-0, IMT Vision - Framework and overall objectives of the future development of IMT for 2020 and beyond," ITU-R, 2015.

3GPP, "Study on Network Controlled Interactive Services; Release 17," 2019.

3GPP TR 26.928, "Extended Reality (XR) in 5G; Release 16".

3GPP TR 22.842, "Study of Network Controlled Interactive Services (NCIS) in the 5G Systems (5GS); Release 17," 2019.

3GPP TR 23.003, "Numbering, addressing and identification," 2020.

Acknowledgments

5G Americas facilitates and advocates for the advancement and transformation of LTE, 5G and beyond throughout the Americas.

5G Americas' Board of Governors members include AT&T, Cable and Wireless, Ciena, Cisco, CommScope, Crown Castle, Ericsson, Intel, Mavenir, Nokia, Qualcomm Incorporated, Samsung, Shaw Communications Inc., T-Mobile USA, Inc., Telefónica, VMware, and WOM.

5G Americas would like to recognize the significant project leadership and important contributions of group leaders Erik Dahlman of Ericsson, and Rapeepat Ratasuk of Nokia, the editor Orlett W. Pearson, Nokia, and the many representatives from member companies on 5G Americas' Board of Governors who participated in the development of this white paper.

The contents of this document reflect the research, analysis, and conclusions of 5G Americas and may not necessarily represent the comprehensive opinions and individual viewpoints of each particular 5G Americas member company. 5G Americas provides this document and the information contained herein for informational purposes only, for use at your sole risk. 5G Americas assumes no responsibility for errors or omissions in this document. This document is subject to revision or removal at any time without notice. No representations or warranties (whether expressed or implied) are made by 5G Americas and 5G Americas is not liable for and hereby disclaims any direct, indirect, punitive, special, incidental, consequential, or exemplary damages arising out of or in connection with the use of this document and any information contained in this document.