



Six Best Practices for Effective Wind Farm Operation

Using Industrial Ethernet Switches to Assure Maximum Uptime

White Paper

Six Best Practices for Effective Wind Farm Operation

Using Industrial Ethernet Switches to Assure Maximum Uptime

Table of Contents

Introduction 3

The Wind Farm Environment..... 3

Why Industrial-Grade Networking? 4

Wind Farm Best Practices 5

- 1. Redundancy 5
- 2. Scalability 6
- 3. Multiple Fiber Support 6
- 4. Temperature Rating 7
- 5. Ease of Use 8
- 6. Advanced Management Tools..... 8

The N-Tron Advantage..... 8

Six Best Practices for Effective Wind Farm Operation

Using Industrial Ethernet Switches to Assure Maximum Uptime

Introduction

A high-speed, industrial-grade network infrastructure offers wind farm operators many benefits, including improved operational management, visibility and access to key data. Real-time data access enables operators to monitor wind turbine uptime, performance and power output – even from remote locations. This data, which is used to track power generation efficiency and trends, provides predictive information that is critical to “Smart Grid” technology. After describing a typical wind farm environment, this white paper will explore six best practices that should be considered for effective wind farm operation.

The Wind Farm Environment

Wind farms operate under conditions typically unsuitable for traditional networking equipment. As such, standard commercial-grade switches and routers designed for climate-controlled data centers and wiring closets should not be used in outdoor locations. They are unable to withstand harsh environments subject to fluctuating temperatures, humidity, vibration, dust and electromagnetic interference from power generation equipment and high voltage transmission lines common to most grid-connected wind farm environments.

Since every kilowatt that a wind generator produces is sold to consumers, network interruptions and downtime result in lost revenue and cannot be tolerated. To avoid the threat of costly maintenance and lost revenue, wind farm operators should deploy reliable, fault-tolerant devices with extended mean time between failure (MTBF) rates. MTBF rates are important because labor expenses are greater in the field compared to labor expenses in the IT world. Even the simplest of switches can be expensive to replace in remote, hard to reach locations.

Why Industrial-Grade Networking?

For effective wind farm operation, complexity and extreme conditions must be taken into consideration. Industrial-grade networking solutions have been designed for extremely rugged environments. In addition to handling harsh conditions and fluctuating temperatures typical of outdoor locations, industrial switches provide highly deterministic performance, which means the data gets from the origin to the destination as rapidly as possible. This proactively guards against failure while maximizing uptime. Built-in redundancy helps to eliminate unexpected points of failures that can negatively impact performance and increase maintenance costs. Designed to protect the infrastructure investment, industrial-grade networks support multiple topologies and scale to accommodate growth as demand increases. They are also easy to deploy and manage. Figure 1 depicts a wind application that uses a redundant Ethernet topology.

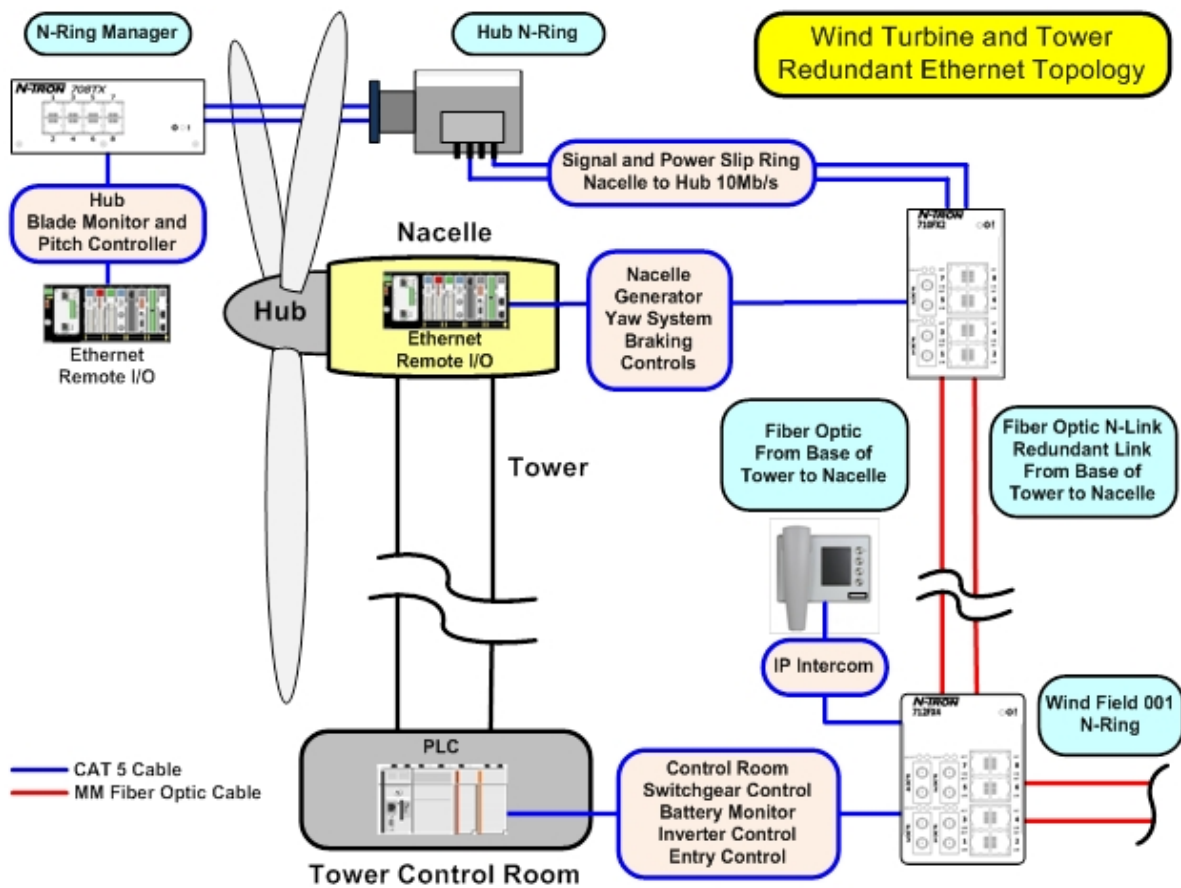

Figure 1. Wind Turbine & Tower Redundant Ethernet Topology

Wind Farm Best Practices

When networking a wind farm, the following six best practices should be considered for optimal deployment and effective wind farm operation:

1. Redundancy

Keeping the network up and running at all times is vital to wind farm efficiency and energy production. The slightest amount of network downtime could lead to service interruptions and lost revenue. One of the most common failure points in any piece of electronics is the power supply. While commercial switches traditionally use cheap wall-mounted AC/DC power supplies that plug into standard wall receptacles, industrial Ethernet switches hard wire two redundantly-independent power supply connections to the DC-power bus and backup power system. Industrial switches with dual-power inputs protect against single points of failure. Therefore, the ideal wind farm network configuration should couple rugged design at the board level with redundant power supplies to prevent malfunctions and downtime caused by equipment failure while protecting against lightning and voltage surges.

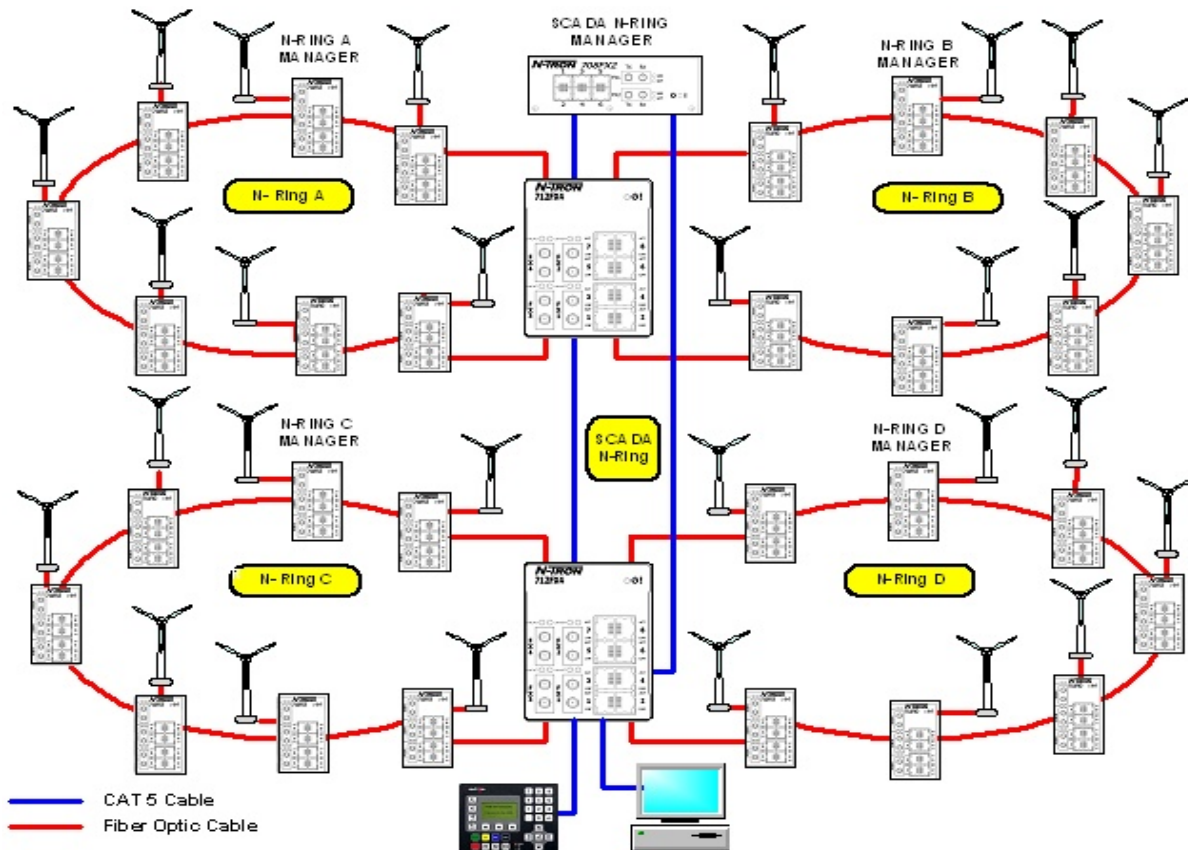

Figure 2. Wind Turbine Network Devices

Cable breaks resulting from human or natural causes and connector or transceiver failure are another common issue that can negatively impact network reliability. In this situation, redundant or “ring” network deployments – such as the N-ring example depicted in Figure 2 above – help to assure network uptime until a maintenance crew is dispatched to address the issue.

2. Scalability

Global energy demand is continuously increasing. With many nations turning to renewable energy sources, the wind industry is experiencing record growth in capacity generation. As demand mounts, the ability to scale is essential for effective and productive wind farm operation.

Ring configurations – supporting up to 250 switches per ring – provide this scalability. Industrial managed switches enable network design flexibility, allowing additional turbines to seamlessly be interconnected to support growth. Offering over 1,000,000+ hours MTBF, industrial switches provide a reliable long-term solution that easily scales to meet changing requirements.

3. Multiple Fiber Support

Most industrial switches provide multi-mode fiber (MMF) and single-mode fiber (SMF). MMF presents a high-bandwidth solution for medium distances – up to 2km – while SMF is used for longer distances ranging from 20 to 80km. The ideal switching solution should flexibly support both MMF and SMF on the same unit so that one turbine can be connected to others at different distances without having to purchase separate fiber switches.

Due to the power generated by the turbine and transmitted through cables in the tower, there is considerable electromagnetic interference (EMI) present in the tower. This can negatively impact communications in networks where copper Cat5e cable is utilized exclusively. Copper cable acts as an antenna and can be adversely affected by EMI. Fiber cable is impervious to EMI. It is important that Industrial Ethernet switches in wind farm applications have three or more fiber ports. Multiple fiber ports on each switch provide for two connections to the redundant ring, plus at least one additional fiber port. This allows for a fiber cable run to the top of the turbine, assuring maximum EMI immunity and Network uptime.

It is also important to assure the network is designed and deployed by experienced installers that are trained to handle and properly terminate fiber optic cable. Improper fiber handling, installation or termination can negatively impact network performance and availability, which ultimately could result in costly repair.

4. Temperature Rating

Power consumption directly relates to temperature ratings, which in turn can impact reliability. Depending on location and time of year, wind turbines are subject to temperatures that fluctuate from extremely hot to frigid. This is one of the reasons why industrial switches are designed to withstand temperatures ranging from -40°C to at least 75°C – and in some cases up to 85°C – without external cooling devices.

It is important to note that not all manufacturers consider power consumption when designing electronics to operate in extreme temperature conditions. In these cases, shortcuts may be used to give the appearance of being able to endure the rugged temperatures required by wind farms. Typical shortcuts include testing boards for performance properties that appear to increase life in warmer temperature environments and then positioning the assembled product as being rated to operate at elevated temperatures. In such cases, the likelihood of failure is high when used under extreme conditions.

Other manufactures build standard product and then test the lot to find units that work at specific temperatures. In this case, the product was not necessarily designed to operate at high temperatures for extended periods of time so early field failure may result. Testing a product for use over short-time periods is not the same as designing an industrially-hardened solution validated to withstand years of service in extreme temperatures.

Cooling systems such as fans and vents can also negatively impact devices operating at extreme temperatures. The typical MTBF of a fan is 25,000 hours, much less than the 1-2 million hours of a good industrial Ethernet switch. A switch utilizing a fan for cooling could automatically shut down if the fan stops working. And, while fans are capable of regulating temperatures through external circulation, humid or caustic air can create issues that shorten the fan, and ultimately the switch lifespan. This problem becomes amplified when a fan is used to push more external air into the device. In this case, what appeared to be a simple, low-cost solution could result in substantial network downtime and maintenance cost.

To ensure reliable performance regardless of operating conditions, it is vital to deploy wind turbine infrastructures based on reputable, industrial-grade networking technology designed and tested to handle fluctuating temperatures and power consumption.

5. Ease of Use

Wind farm operators should select industrial switches ready to use out of the box that require little – if any – configuration work. They should source easy-to-use switches that deliver:

- Plug-and-play capabilities that automatically detect network changes
- Port speed auto-negotiation, MDI/MDIX auto-crossover and TD/RD auto polarity that allow the same cable to be used regardless of units connected
- Comprehensive networking features such as intuitive software and advanced management tools
- Command line interface (CLI) over a console port along with a web-based graphical user interface (GUI) that supports network specialists and other users.

6. Advanced Management Tools

To complement redundancy, scalability, fiber support, temperature rating and ease of use, advanced management tools such as multicast and VLAN support, overlapping VLAN, Quality of Service, Automatic IGMP snooping, and DHCP help to improve wind farm operation by providing ease of configuration and management and real-time access to key network data. Industrial switches deliver deterministic networking in a rugged package to enable the automated monitoring and maximization of network uptime, performance, traffic patterns and power output – even from remote locations where manual monitoring can prove costly and resource intensive. This enables power generation tracking, trending and reporting that helps optimize the network to ensure smooth wind farm operation.

The N-Tron Advantage

For more than a decade, N-Tron has been providing leading industrial connectivity solutions to customers and markets worldwide. N-Tron's industrial Ethernet switches combine deterministic performance with rugged reliability to provide a “best of both worlds” solution for harsh, outdoor and remote industrial applications such as wind farms. These switches enable wind farm operators to increase business productivity while reducing operating expenses and total cost of ownership. To learn more, please visit www.n-tron.com.



www.n-tron.com

Connect. Monitor. Control.

3101 International Drive, Building 6
Mobile, AL 36606 USA
+1 (251) 342-2164