

ABOUT US

Starting with a small but experienced workforce of more than 20 years, Star Electrical Components has quickly established itself as one of India's leading dip moulding and dip coating manufacturer.

All operations right from product design to packaging of finished products are done in-house, with necessary quality checks at each stage. With in-house formulations, we can customise product's thickness, colour and hardness according to customer's requirements. All our products can also be provided with client's logo/brand. With modern CAD design facilities and experienced design engineers, we can ensure quick prototyping. With quality certifications like ISO 9000:2015 our customers can expect to get best quality on time, every time.

All our products are RoHS 3 (July 22, 2019), LSF (Low Smoke Flame), LSZH (Low Smoke Zero Halogen) compliant.

Our quality has been appreciated and awarded by domestic as well as international clients.

You can send us a sample, drawing and our product design team will provide you with complete assistance - from design to finished product.



CONTENTS

1. Grips
2. Cable Gland Shrouds
3. Bus bar shrouds
4. Petrol pump covers
5. Battery terminals
6. Bellows
7. Terminal Caps, Coupler covers
8. Protection caps
9. Dip coatings
10. Water tap connectors
11. Customized product

CABLE GLAND

Cable gland shrouds are used to improve electrical safety by providing insulation protection up to xx KV/mm. The shrouds also improve life of the cable glands by providing dust and water protection up to IP 66 Rating.

The shrouds are available in two certified material grades –

- LSF (Low Smoke and Flame) (see certificate)
- LSZH (Low Smoke Zero Halogen) (see certificate)

Standard colours available are Black and Grey but we can supply shrouds in any colour required. We can also customize shrouds to the required length hardness and thickness.



BW /A1-A2 Shrouds				
	Gland Ref	Size	SHROUD ID -d	SHROUD St.length H2
	BW /A1-A2 Shrouds			
BW-2023	2023	20S	23	35
BW-2025	2025	20mmS	25	35
BW-2026	2026	20B	26	40
BW-2027	2027	20mmL	27	40
BW-2030	2030	20L	30	40
BW-2533	2533	25S	33	45
BW-2535	2535	25mmL	35	55
BW-2538	2538	25L	38	40
BW-3243	3243	32S	43	50
BW-3246	3246	32L	46	50
BW-3248	3248	32mmL	48	55
BW4000	40mm		40	60
BW-4053	4053	40S	53	50
BW-4055	4055	40L	55	55
BW-4058	4058	40mmL	58	55
BW-5064	5064	50S	64	60
BW-5068	5068	50L	68	70
BW-6379	6379	63S	79	85
BW-6382	6382	63mmL	82	70
BW-6385	6385	63L	85	80
BW-7595	7595	75S	95	70
BW-75103	75103	75L	103	100
BW-7599	7599	75mmL	99	80
BW-88118	88118	88L	118	90
BW-1621	2021		21	35
BW-2032	2032		32	45
BW-5063	5063		63	70
BW-6379	6379		79	75
BW-6388	6388		88	75
BW-70MM	70		70	70
BW-7300	7300		73	70
BW-75106	75106		106	90
BW-88113	88113		113	95

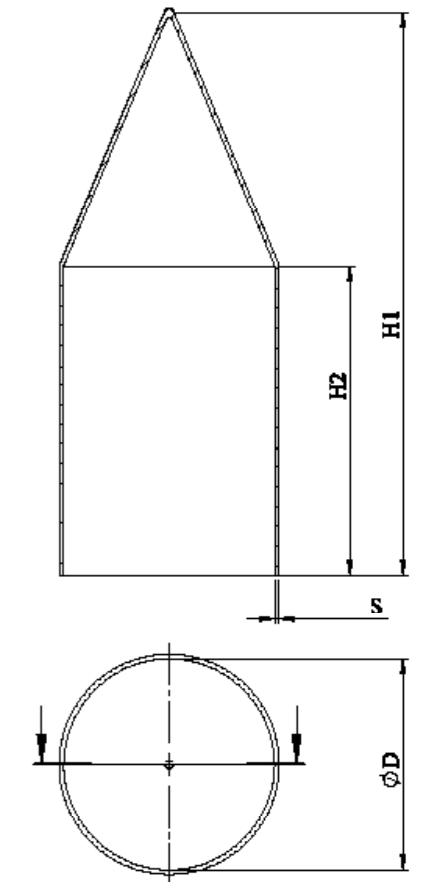

WATER NOZZLES

Water nozzles enable quick and firm connection of a hose to a tap. The nozzle is flexible and can accommodate various sizes of tap ends. They can be manufactured in various colours as per customer requirement.



BELLOWS

PVC bellows are used to provide excellent protection for movable parts. Due to the design and flexibility of the product, the bellow expands and contracts thereby providing protection for the whole range of motion. Unlike rubber bellows, PVC bellows do not harden and are extremely durable, making them a preferred choice. With metal straps in place, our bellows can provide dust and water protection up to IP66. The bellows can be customized in colour, hardness and thickness as per customer's requirement. We also provide full assistance for new design development.



GRIPS

Vinyl grips are used to enable comfortable and ergonomic operation of all sort of handles and levers. Our grips not only provide electrical and thermal insulation, but also improve life of levers by providing dust and water protection. Ergonomic shape along with glossy finish help improve aesthetic value of the product. The valves can be customised for various size, colour, hardness and thickness and by nature of dip moulding process, we can provide samples in very short time. The grips can also be printed with operational instructions (ON / OFF) along with customer's brand.



BUSBAR SHROUDS

Bus bar shrouds are used to improve electrical safety by providing insulation protection up to xx KV/mm. The shrouds also improve life of the bus bar by providing dust and water protection up to IP 66 Rating.

The shrouds are available in two certified material grades –

- LSF (Low Smoke and Flame) (see certificate)
- LSZH (Low Smoke Zero Halogen) (see certificate)

Standard colours available are Black and Red but we can supply shrouds in any colour required. We can provide full design assistance for bus bar shrouds according to customer requirement.



FUEL DISPENSER NOZZLE

Our fuel nozzle covers can provide adequate nozzle protection up to IP66 rating besides helping in identification of type of fuel being dispensed (Petrol – Green /Diesel - Blue etc.) We can also customize the product for various shape, hardness and colour required.



BATTERY TERMINALS

Battery Terminal covers are used to provide insulation and prevent accidental shorting of battery. It can provide protection up to IP66 rating and also improve operator safety. The covers are manufactured in Red (+) and Black (-) colour as per industry standard and prevent accidental reverse polarity connection. The covers can be also designed and manufactured according to customer requirement. The covers provide excellent electrical insulation of xx kV/mm. (Material test report).



PROTECTION CAPS

Terminal Connector Covers: Terminal Connectors are used to make quick electrical connections. Terminal caps covers provides dust and water protection to the terminals up to IP66 rating. They are usually provided in transparent or tea-blue colour but can be customized to suit customer requirement.



TERMINAL CAPS

Terminal Connector Covers: Terminal Connectors are used to make quick electrical connections. Terminal caps covers provides dust and water protection to the terminals up to IP66 rating. They are usually provided in transparent or tea-blue colour but can be customized to suit customer requirement.



DIP COATING

Dip Coating: We can coat any metallic product with vinyl to improve its life, ergonomic operation and aesthetic value. We can customize coating colour, thickness and hardness according to customer requirement.

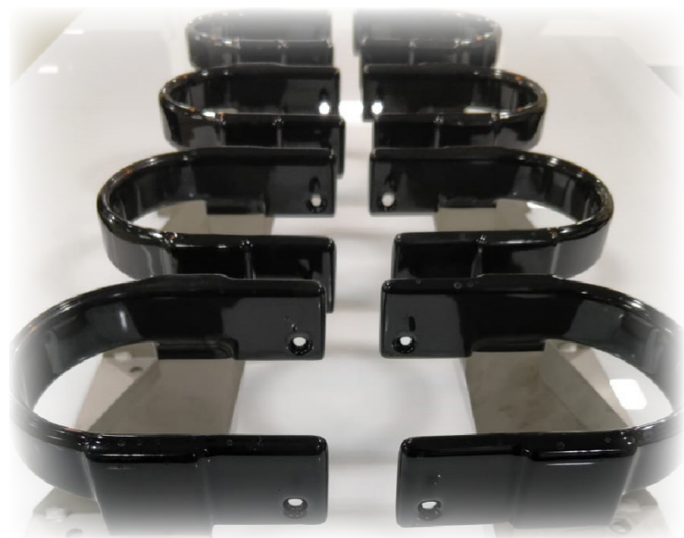

CUSTOM PRODUCT

We can manufacture any customised product as per your requirement - in dimension, color, thickness etc. We provide design assistance right from concept to final product. Please feel free to contact us.

CERTIFICATES



Scanned by CamScanner



Scanned by CamScanner

Address : Unit No.7, Building - 5 - Shrishthi, Square Industrial Park, Tungarphata - Sativali - Nr.NH-8,
Vawsai East,Dist. Palghar, Maharashtra - 401208

Contact : +91 9820985206