

**Variable
Displacement
Vane Pump**
變量葉片泵





PAG.3 /
變量葉片泵附循環泵系列
Variable Displacement Vane Pump
With Cooling Circulation Pump



PAG.19 /
變量葉片泵+外啮合齒輪泵
Variable Displacement Vane Pump +
Gear Pump



PAG.7 /
變量葉片泵系列
Variable Displacement Vane Pump



PAG.21 /
小型化油壓單元
Minimization Hydraulic Power Unit



PAG.13 /
變量葉片泵花鍵系列
Variable Displacement Vane Pump
Splined Shaft



PAG.23 /
節能變頻油壓單元
Energy Saving Hydraulic Power Unit



PAG.17 /
雙聯變量葉片泵
Double Variable Displacement
Vane Pump

PAG.25 /
使用及注意事項
Notice

How To Buy

如何選購

VCM SF 20 C ※ ※ 6CG 1 0 A
1 2 3 4 5 6 7 8 9 10

1 變量葉片泵系列 Variable Displacement Vane Pump Series

2 葉片泵系列編號 Variable Displacement Vane Pump Models

SF SFI SFC SM DF

3 泵流量 Displacement

12L/min 20L/min 30L/min 40L/min

4 最大壓力 Pressure ranges

SF SFC SM

AS: 10 kgf/cm²

A: 20 kgf/cm² A: 20 kgf/cm² A: 35 kgf/cm²

B: 35 kgf/cm² B: 35 kgf/cm² B: 70 kgf/cm²

C: 55 kgf/cm² C: 55 kgf/cm² C: 105 kgf/cm² (僅有 30L/min)

D: 70 kgf/cm² D: 70 kgf/cm² D: 140 kgf/cm² (Only 30L/min)

5 雙聯後泵流量編號 Secondary Pump Displacement Range

無: NO

同 3 編號方式 With three numbering

6 雙聯後泵壓力編號 Secondary Pump Pressure Range

無: NO

同 4 編號方式 With four numbering

7 組合系列 Combination

冷卻循環泵 Cooling circulation pump: 4CG、6CG

高壓齒輪泵 External gear pump: EGA (請參照NO.20頁) (Refer to page. 20)

8 設計編碼 Design No.

1: 標準 12.7mm

2: 標準 不可調流 12.7mm

3: 大軸心 19.05mm

4: 大軸心 不可調流 19.05mm

5: 內流型 Inward Flowing

9 牙規 Thread Type

0: 標準PT型 PT type

1: 直牙BSPT型 BSPT type

2: 管用NPT型 NPT type

10 花鍵 Splined Shaft

無: 標準直鍵 None: Standard

A: 7T B: 9T

Variable Displacement Vane Pump With Cooling Circulation Pump

變量葉片泵附循環泵系列

VCM-**SF**
SM/CG

油壓記號

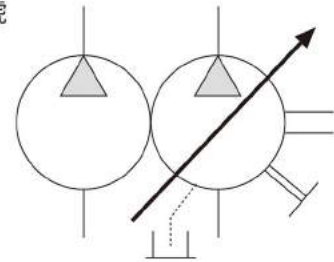

SYMBOL



型式號碼/MODEL CODE

VCM - SF - 20 - ※ - 4CG - ※

設計號碼 Design No.

SF

SM

20 : 12, 20L

30 : 30, 40L

30 : 30, 40L

特殊規格參照PAG.2 **8**、**9**項

冷卻循環泵系列 Cooling circulation pump type

4CG(4L/min)

6CG(8L/min)

壓力範圍 Pressure Range

SF

SM

A : 20 kgf/cm²

A : 35 kgf/cm²

B : 35 kgf/cm²

B : 70 kgf/cm²

C : 55 kgf/cm²

C : 105 kgf/cm² (僅有 30L/min)

D : 70 kgf/cm²

D : 140 kgf/cm² (Only 30L/min)

泵排量 Displacement at 1800rpm

12L/min

20L/min

30L/min

40L/min

系列號碼 Series .no.

SF

SM

低壓變量葉片泵

中壓變量葉片泵

葉片泵系列 Variable displacement Vane Pump Series

型式 MODEL	泵排量 (無負荷時) DELIVERY AT NO LOAD (L/min)		壓力調整範圍 PRESSURE ADJ. RANGE (kgf/cm ²)	容許回轉速 SHAFT SPEED RANGE (rpm)		最高壓力 MAX. PRESSURE (kgf/cm ²)	重量 WEIGHT (kg)
	1800rpm	1500rpm		最高 MAX.	最低 MIN.		
SF-12A	12	10	10-20	1800	800	20	5.0
SF-12B			15-35			35	
SF-12C			30-55			55	
SF-12D			50-70			70	
SF-20A	20	17	10-20	1800	800	20	5.0
SF-20B			15-35			35	
SF-20C			30-55			55	
SF-20D			50-70			70	
SF-30A	30	25	10-20	1800	800	20	9.0
SF-30B			15-35			35	
SF-30C			30-55			55	
SF-30D			50-70			70	
SF-40A	40	35	10-20	1800	800	20	9.0
SF-40B			15-35			35	
SF-40C			30-55			55	
SF-40D			50-70			70	
SM-30A	30	25	15-35	1800	800	35	9.7
SM-30B			20-70			70	
SM-30C			50-105			105	
SM-30D			70-140			140	
SM-40A	40	35	15-35	1800	800	35	9.7
SM-40B			20-70			70	

冷卻循環泵 Cooling circulation pump

型式 MODEL	泵排量 (無負荷時) DELIVERY AT NO LOAD (L/min)		壓力調整範圍 PRESSURE ADJ. RANGE (kgf/cm ²)	容許回轉速 SHAFT SPEED RANGE (rpm)	
	1800rpm	1500rpm		最高MAX.	最低MIN.
4CG	4	3	3	1800	800
6CG	6	4			

產品特性/CHARACTERISTIC

- 獨一無二的專利連結設計，縮短變量葉片泵和冷卻循環泵長度，體積更小，造型更輕巧。冷卻循環泵吸取油箱內的液壓油，輸送到冷卻系統後回到油箱，不斷循環，有效達到降低油溫的功能。
 - 冷卻循環泵內建壓力設定，輸出壓力保持在 3kgf/cm²，有效保護冷卻系統管路。
 - 經實驗證明，搭配合適的冷卻器，降溫效果比傳統冷卻回油(DRAN)更加明顯。
 - 油箱小型化，節省空間，減少液壓油容量，降低成本。
- Unique and patented attachment design, it reduces overall length and dimension after attached to a variable displacement wane pump, the entire combination became more compact. This cooling circulation pump intake oil from oil reservoir, deliver to cooling system. It effectively reduced oil temperature under continuous process of circulation.
 - Cooling circulation pump has build-in pressure setting, maintaining pressure at 3 kgf/cm², protect pipeline of cooling system.
 - Rapid testes proven, to combine with proper cooler, it performed better cooling efficiency then cooling variable vane pump's drain by far.
 - By reducing size of reservoir, it could save space and volume of hydraulic oil. At the end, it saved cost.

Variable Displacement Vane Pump With Cooling Circulation Pump

變量葉片泵附循環泵系列

VCM-SF
SM/CG

外型尺寸 / MEASUREMENT

VCM - SF - 12 - * - *CG - 20

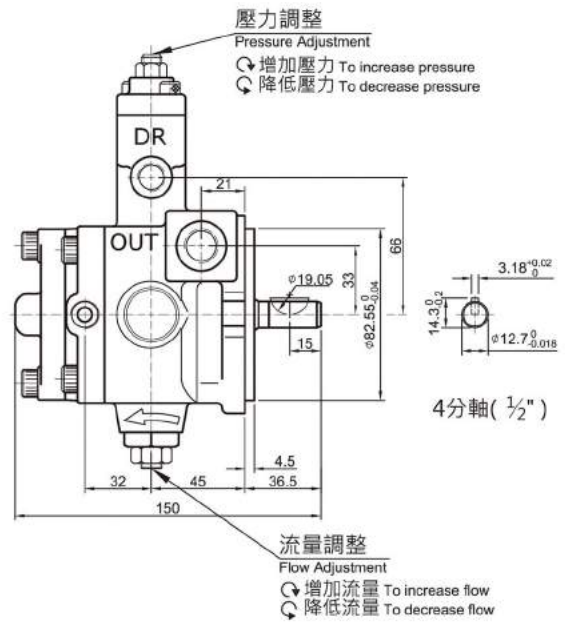
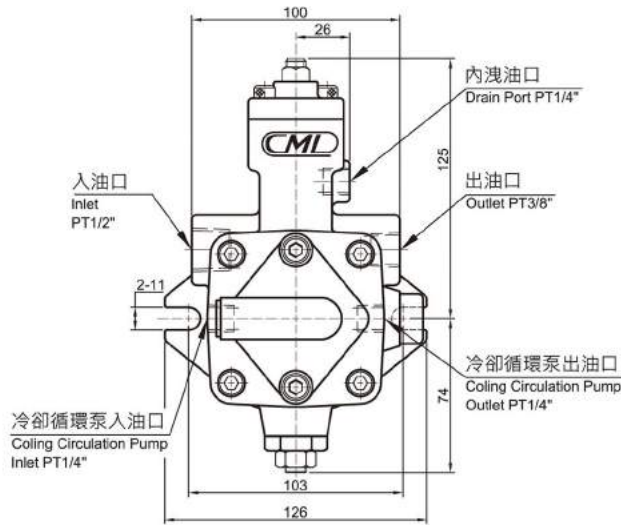

VCM - SF - 30 - * - *CG - 30

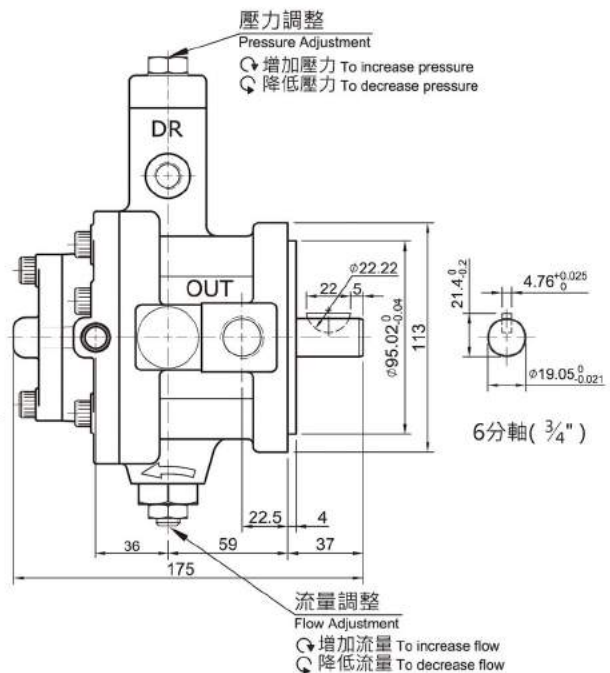
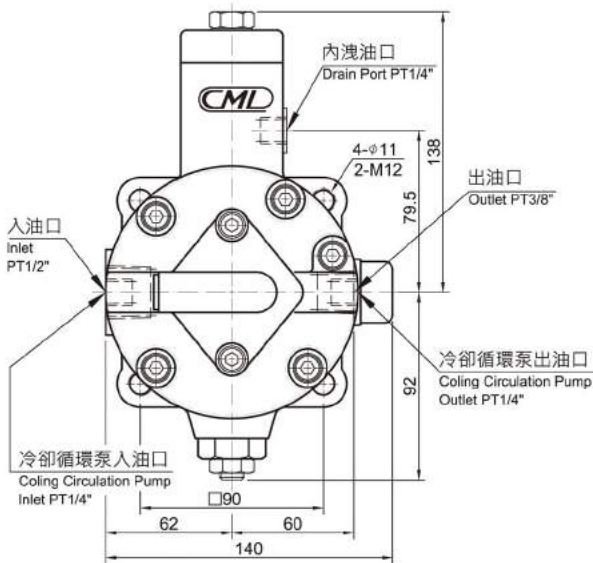

外型尺寸 / MEASUREMENT

VCM - SM - 30 ※ - 4CG - 20

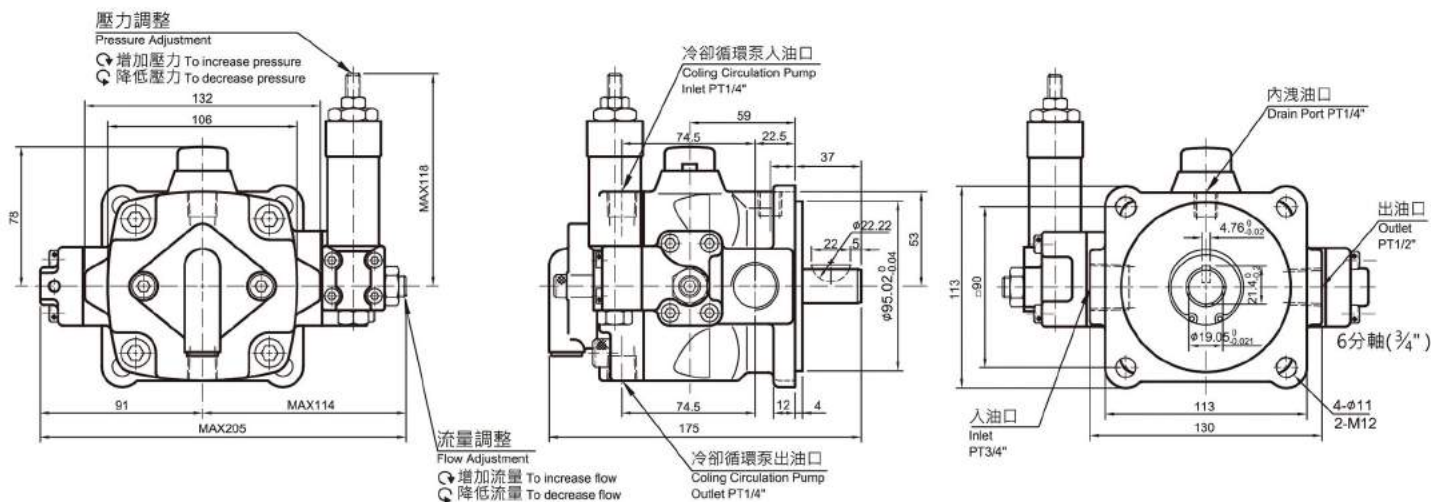

性能曲線圖 / PERFORMANCE CURVES

VCM - SF - 20 ※ - 4CG - 20

測試條件 Testing condition
 操作用油 Hydraulic oil: ISO VG32
 馬達轉速 Speed: 1800 rpm
 油箱容積 Capacity of tank: 30L
 室溫 Ambient Temperature: 30°C

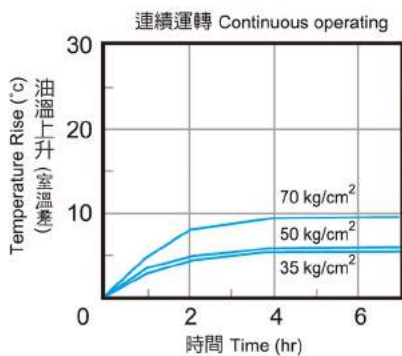

Continuous operated cylinder (Ø20xØ40x250mm)
 W/cylinder working cycle: 12 strokes/min.
 連續操作CYLINDER (Ø20xØ40x250mm)
 作動頻率12次往返 / 每分鐘

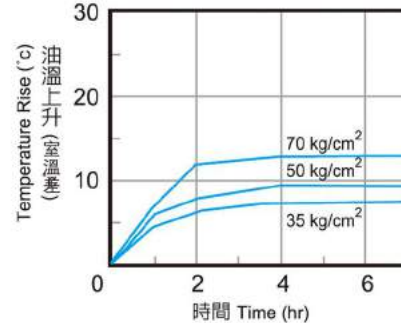

VCM - SF - SM - 30 ※ - 4CG - 30

測試條件 Testing condition
 操作用油 Hydraulic oil: ISO VG32
 馬達轉速 Speed: 1800 rpm
 油箱容積 Capacity of tank: 40L
 室溫 Ambient Temperature: 30°C

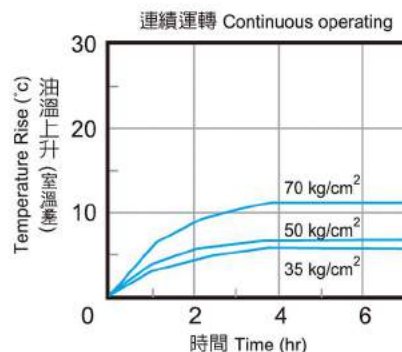

Continuous operated cylinder (Ø20xØ40x250mm)
 W/cylinder working cycle: 12 strokes/min.
 連續操作CYLINDER (Ø20xØ40x250mm)
 作動頻率12次往返 / 每分鐘

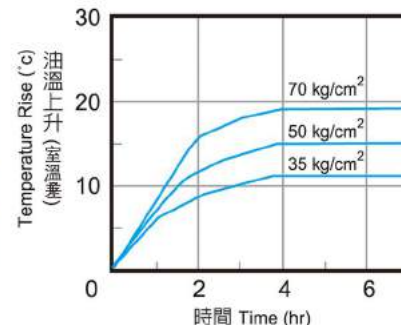

Variable Displacement Vane Pump

變量葉片泵系列

VCM-SF/SM/SFC



SF-12/20



SF-30/40



SFC-30/40

油壓記號

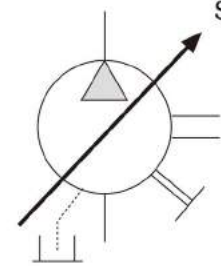

SYMBOL



SM-30/40

型式號碼 / MODEL CODE

VCM - SF - 20 - B - 10 - ※

鍵型 (Button to select)

參照 PAG.2 [10] 項

設計號碼 Design No.

請參照 PAG.2 [8]、[9] 項

壓力範圍 Pressure Range

SF	SFC	SM
AS : 10 kgf/cm ²		
A : 20 kgf/cm ²	A : 20 kgf/cm ²	A : 35 kgf/cm ²
B : 35 kgf/cm ²	B : 35 kgf/cm ²	B : 70 kgf/cm ²
C : 55 kgf/cm ²	C : 55 kgf/cm ²	C : 105 kgf/cm ² (僅有30L/min)
D : 70 kgf/cm ²	D : 70 kgf/cm ²	D : 140 kgf/cm ² (Only 30L/min)

泵排量 Displacement at 1800rpm

12L/min	20L/min	30L/min	40L/min
---------	---------	---------	---------

系列號碼 Series .no.

SF	SFC	SM
低壓變量葉片泵	附止回型變量葉片泵	中壓變量葉片泵

葉片泵系列 Variable displacement Vane Pump Series

 技術資料/ TECHNICAL DATA

型式 MODEL	泵排量 (無負荷時) DELIVERY AT NO LOAD (L/min)		壓力調整範圍 PRESSURE ADJ RANGE (kgf/cm ²)	容許回轉速 SHAFT SPEED RANGE (rpm)		最高壓力 MAX. PRESSURE (kgf/cm ²)	重量 WEIGHT (kg)
	1800rpm	1500rpm		最高 MAX.	最低 MIN.		
SF-12AS	12	10	5-10	1800	800	10	5.0
SF-12A			10-20			20	
SF-12B			15-35			35	
SF-12C			30-55			55	
SF-12D			50-70			70	
SF-20AS	20	17	5-10	1800	800	10	5.0
SF-20A			10-20			20	
SF-20B			15-35			35	
SF-20C			30-55			55	
SF-20D			50-70			70	
SF-30AS	30	25	5-10	1800	800	10	9.0
SF-30A			10-20			20	
SF-30B			15-35			35	
SF-30C			30-55			55	
SF-30D			50-70			70	
SF-40AS	40	35	5-10	1800	800	10	9.0
SF-40A			10-20			20	
SF-40B			15-35			35	
SF-40C			30-55			55	
SF-40D			50-70			70	
SM-30A	30	25	15-35	1800	800	35	9.7
SM-30B			20-70			70	
SM-30C			50-105			105	
SM-30D			70-140			140	
SM-40A	40	35	15-35	1800	800	35	9.7
SM-40B			20-70			70	

 產品特性/FEATURE

- | | |
|--|---|
| <ol style="list-style-type: none"> 1. 高壓力、高效率、運轉平順。 2. 低噪音、低振動，符合低噪音工作環境要求。 3. 反應靈敏，動作精確度高。 4. SM系列壓力補償型調整裝置，提供穩定的操作特性。 5. 結構簡單，容易維護及操作。 6. 使用壽命長。 7. 體積小，節省空間，可直接連結馬達使用。 | <ol style="list-style-type: none"> 1. High efficiency, high-pressure, operation. 2. Extremely low vibration and noise level. 3. Instant and sharp cut-off characteristics. 4. Sturdy structure for high efficiency and long service life. 5. Easy adjustment in handling and maintenance. 6. Very low noise when operating. 7. Sturdy structure for high efficiency and long service life. |
|--|---|

Variable Displacement Vane Pump

變量葉片泵系列

VCM-SF/SM/SFC

外型尺寸 / MEASUREMENT

VCM - SF - $\frac{12}{20}$ - ※ - 10 - ※

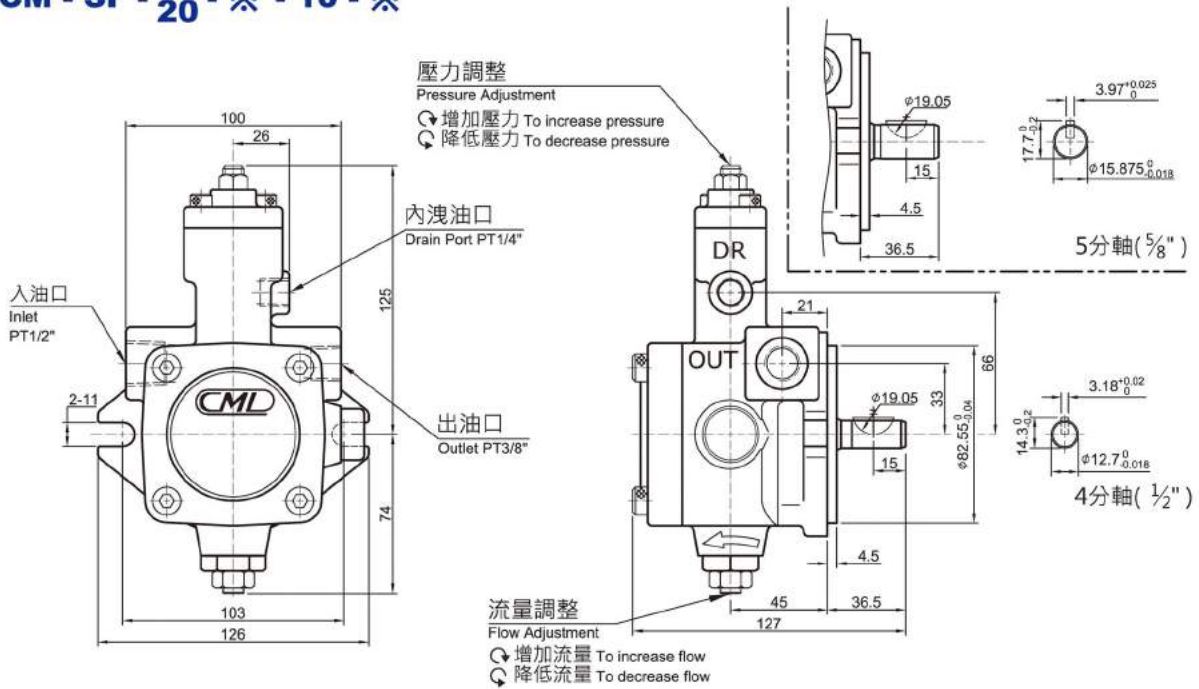

VCM - SF - $\frac{12}{20}$ - ※ - 10 - ※

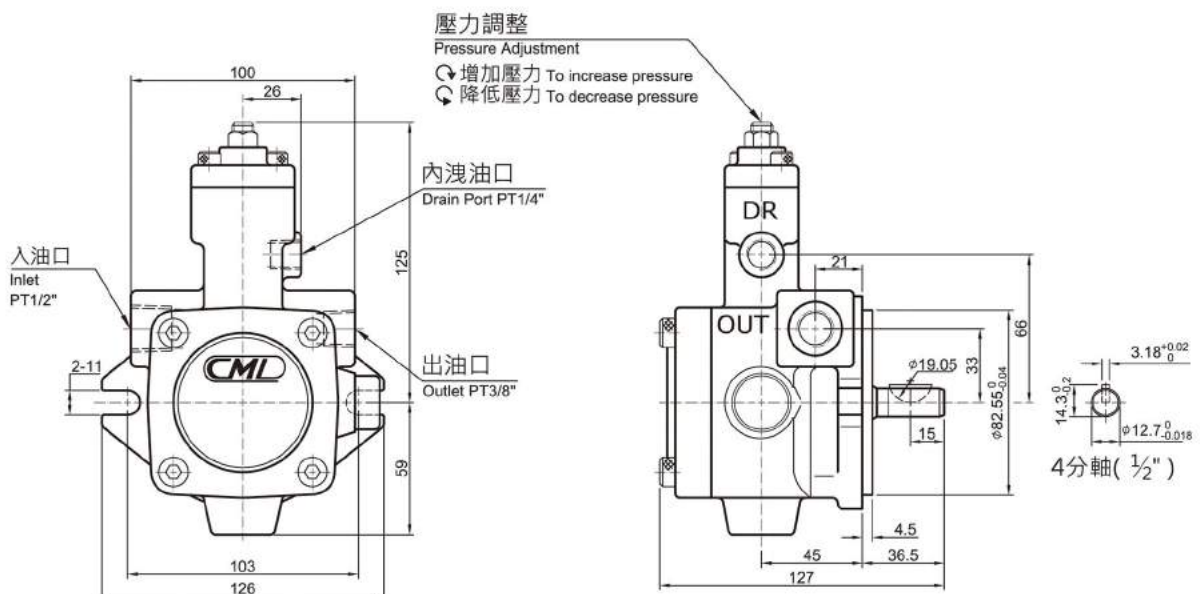

VCM - SF - 30 - ※ - 20 - ※

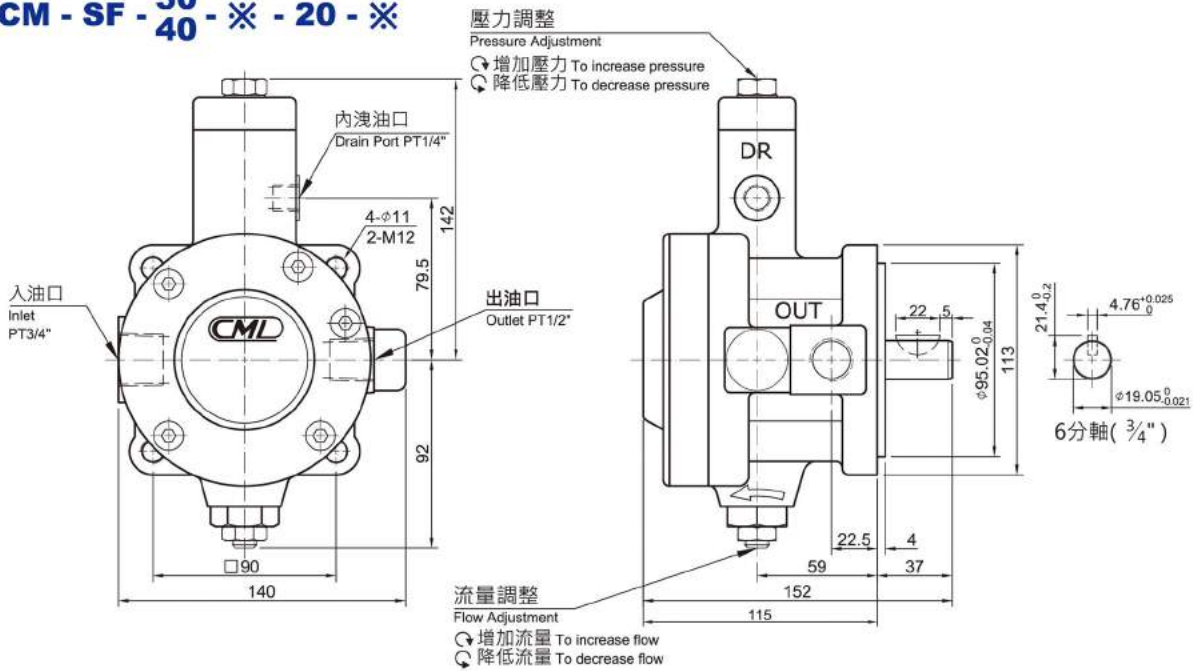

VCM - SF - 30 - ※ - 20 - ※

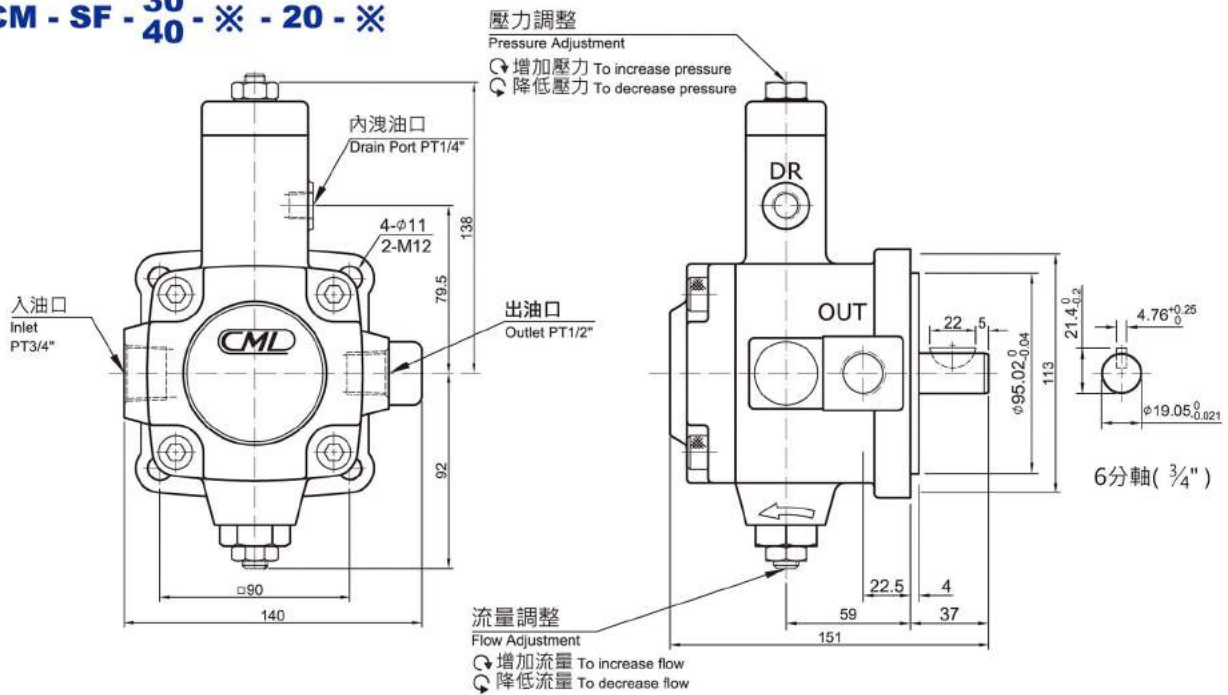

Variable Displacement Vane Pump

變量葉片泵系列

VCM-SF/SM/SFC

外型尺寸 / MEASUREMENT

VCM - SFC - 30 - ※

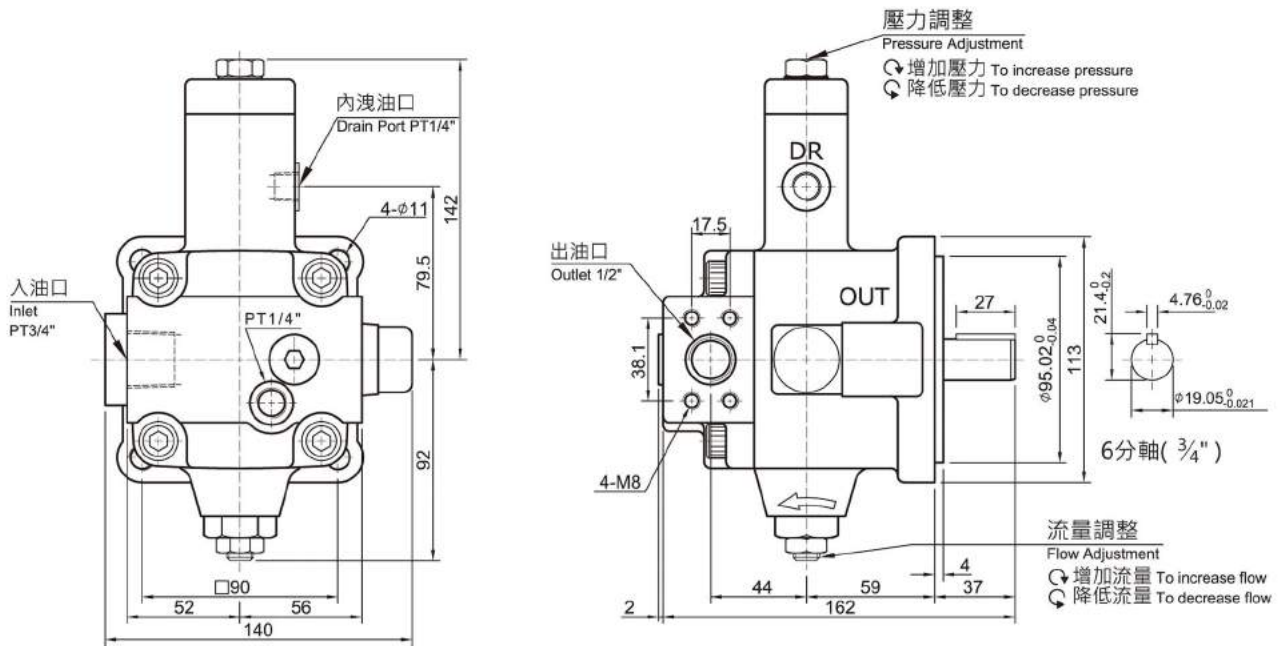

VCM - SM - 30 - ※

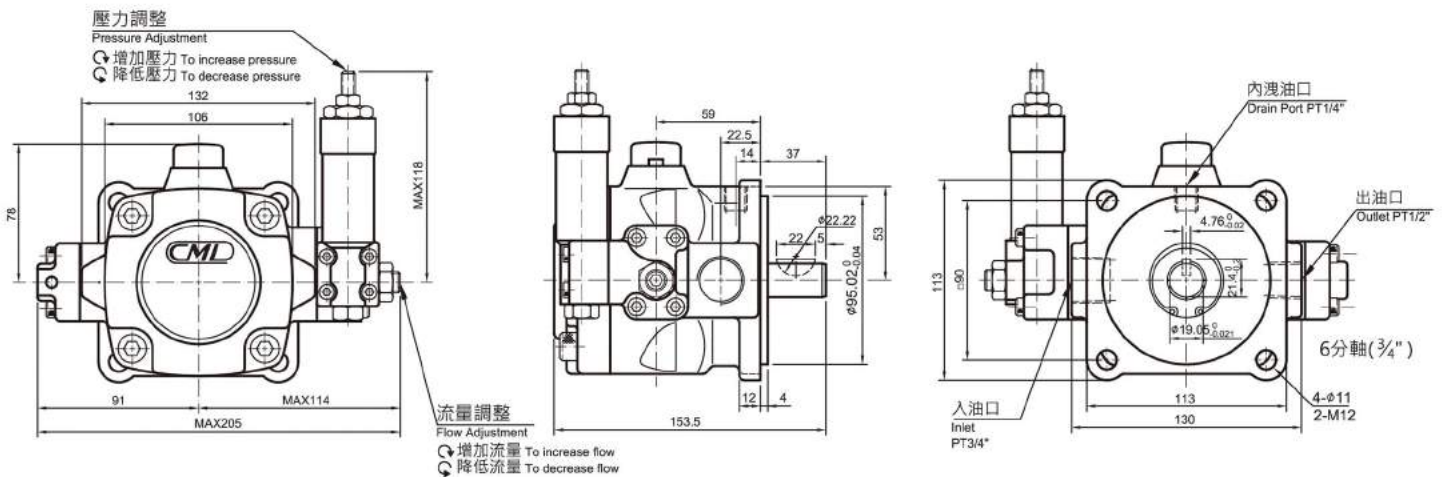

 性能曲線圖/PERFORMANCE CURVES

SF - 12 ※ -10

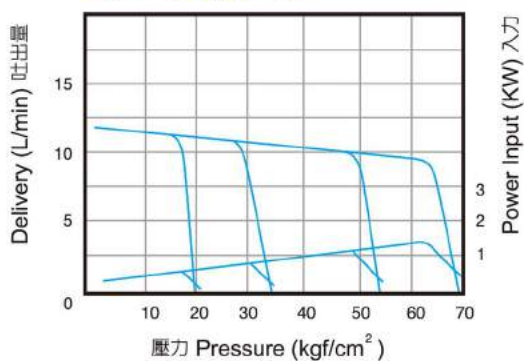

SF - 20 ※ -10

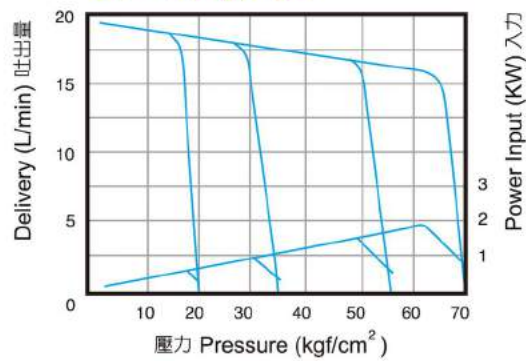

SF - 30 ※ -20

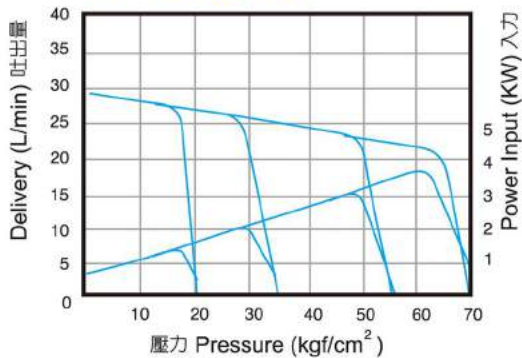

SF - 40 ※ -20

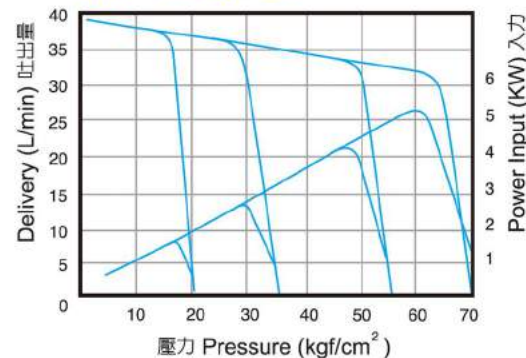

SM - 30 ※ -20

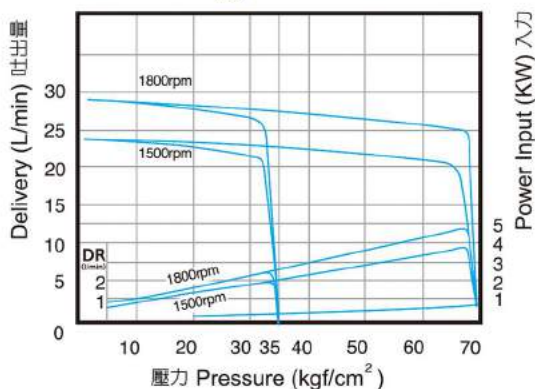

SM - 40 ※ -20

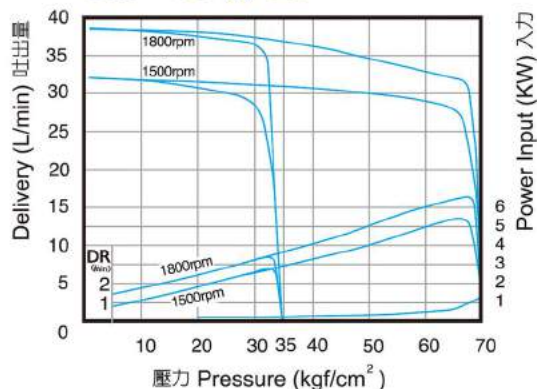

測試條件：液壓油溫度40°C±5°C，液壓油等級ISO VG 46。

Testing conditions: Oil temperature 40°C±5°C, hydraulic oil ISO VG 46.

Variable Displacement Vane Pump Splined Shaft

變量葉片泵花鍵系列

VCM-SF ※※-※ ^A 外花鍵
 SF II-※-※ ^B 內花鍵

油壓記號

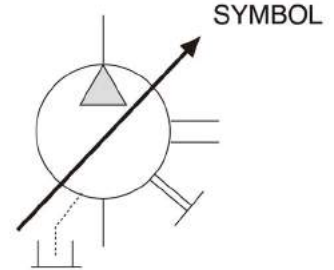

SF-12/20-※-10 ^A_B



SF-30/40-※-10 ^A_B



SF II-12/20



SF II-30/40

◎ 型式號碼 / MODEL CODE

VCM - SF - 20 - B - 10 - ※

鍵型 (Button to select)

參照PAG.2 [10] 項

設計號碼 Design No.

請參照PAG.2 [8]、[9] 項

壓力範圍 Pressure Range

SF	SFII
AS : 10 kgf/cm ²	
A : 20 kgf/cm ²	A : 20 kgf/cm ²
B : 35 kgf/cm ²	B : 35 kgf/cm ²
C : 55 kgf/cm ²	C : 55 kgf/cm ²
D : 70 kgf/cm ²	D : 70 kgf/cm ²

泵排量 Displacement at 1800rpm

12L/min	20L/min	30L/min	40L/min
---------	---------	---------	---------

系列號碼 Series .no.

SF	SFII
低壓變量葉片泵	附止回型變量葉片泵

葉片泵系列 Variable displacement Vane Pump Series

技術資料/ TECHNICAL DATA

型式 MODEL	泵排量(無負荷時) DELIVERY AT NO LOAD (L/min)		壓力調整範圍 PRESSURE ADJ RANGE (kgf/cm ²)	容許回轉速 SHAFT SPEED RANGE (rpm)		最高壓力 MAX. PRESSURE (kgf/cm ²)	重量 WEIGHT (kg)
	1800rpm	1500rpm		最高 MAX.	最低 MIN.		
SF-12AS	12	10	5-10	1800	800	10	5.0
SF-12A			10-20			20	5.0
SF-12B			15-35			35	5.0
SF-12C			30-55			55	5.0
SF-12D			50-70			70	5.0
SF-20AS	20	17	5-10	1800	800	10	5.0
SF-20A			10-20			20	5.0
SF-20B			15-35			35	5.0
SF-20C			30-55			55	5.0
SF-20D			50-70			70	5.0
SF-30AS	30	25	5-10	1800	800	10	9.0
SF-30A			10-20			20	9.0
SF-30B			15-35			35	9.0
SF-30C			30-55			55	9.0
SF-30D			50-70			70	9.0
SF-40AS	40	35	5-10	1800	800	10	9.0
SF-40A			10-20			20	9.0
SF-40B			15-35			35	9.0
SF-40C			30-55			55	9.0
SF-40D			50-70			70	9.0

產品特性/FEATURE

- | | |
|---|---|
| <ol style="list-style-type: none"> 1. 高壓力、高效率、運轉平順。 2. 低噪音、低振動，符合低噪音工作環境要求。 3. 反應靈敏，動作精確度高。 4. 結構簡單，容易維護及操作。 5. 使用壽命長。 6. 體積小，節省空間，可直接連結馬達使用。 | <ol style="list-style-type: none"> 1. High efficiency, high-pressure, operation. 2. Extremely low vibration and noise level. 3. Instant and sharp cut-off characteristics. 4. Easy adjustment in handling and maintenance. 5. Very low noise when operating. 6. Sturdy structure for high efficiency and long service life. |
|---|---|

Variable Displacement Vane Pump Splined Shaft

變量葉片泵花鍵系列

VCM-SF/SF II

外型尺寸 / MEASUREMENT

VCM - SF - 12/20 - ※ - 10 - A/B 外花鍵系列

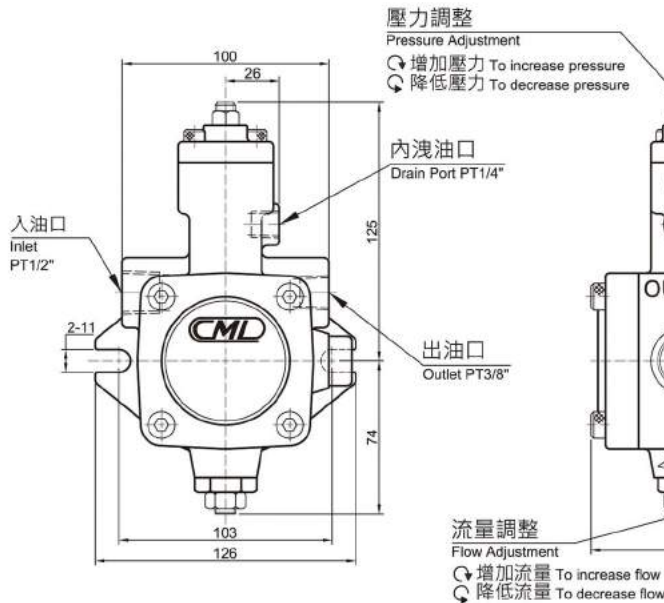

依美國ANSI B92.1規範 精度等級：5級
According to the US ANSI B92.1 specifications
Class of accuracy: Class 5

模數	Module	D.P16/32	D.P.16/32
壓力角	Pressure Angle	30°	30°
齒數	Number of Teeth	7	9
節圓直徑	Pitch Diameter	φ 11.113	φ 14.2875
最大值徑	Maximum Diameter	φ 12.7 ⁰ _{-0.04}	φ 15.875 ⁰ _{-0.05}
最小值徑	Minimum Diameter	φ 8.636(MAX)	φ 11.811(MAX)

VCM - SF - 30/40 - ※ - 20 - A/B

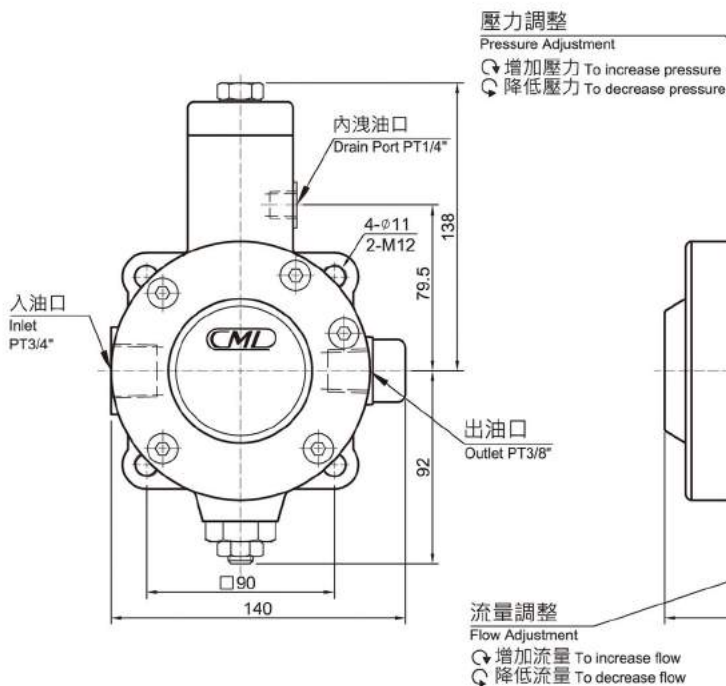

依美國ANSI B92.1規範 精度等級：5級
According to the US ANSI B92.1 specifications
Class of accuracy: Class 5

模數	Module	D.P16/32	D.P.16/32
壓力角	Pressure Angle	30°	30°
齒數	Number of Teeth	9	9
節圓直徑	Pitch Diameter	φ 14.2875	φ 14.2875
最大值徑	Maximum Diameter	φ 15.875 ⁰ _{-0.05}	φ 15.875 ⁰ _{-0.05}
最小值徑	Minimum Diameter	φ 11.811(MAX)	φ 11.811(MAX)

VCM - SF II - 12 - ※ - 10 內花鍵系列

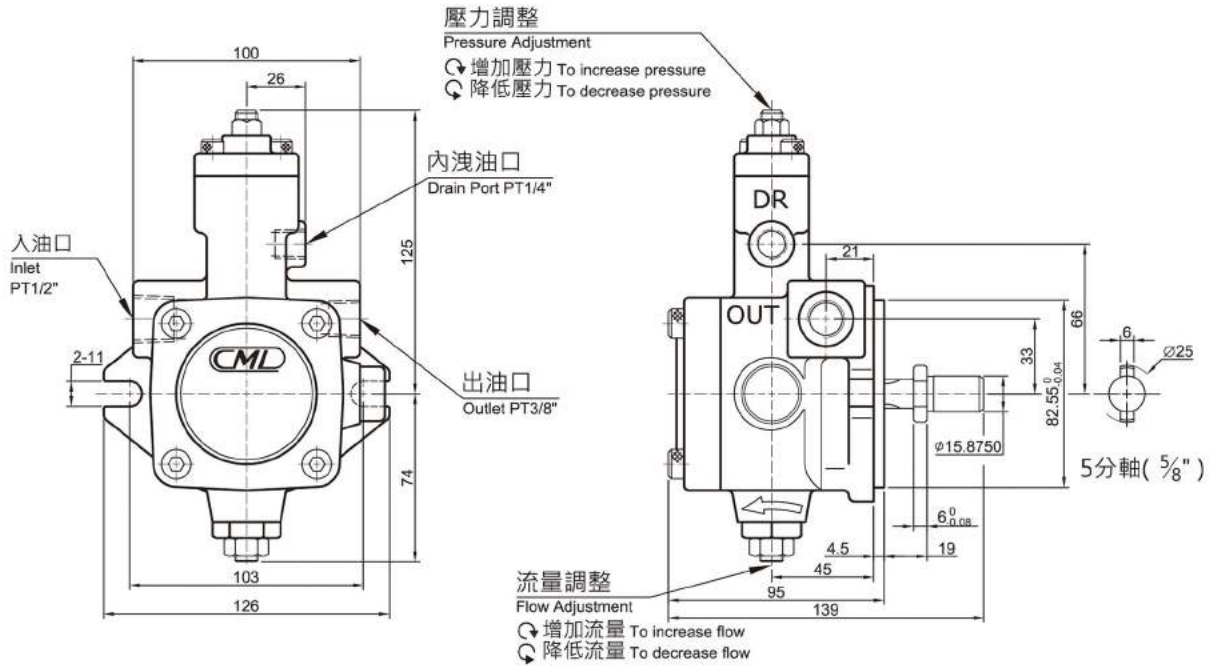

VCM - SF II - 30 - ※ - 20

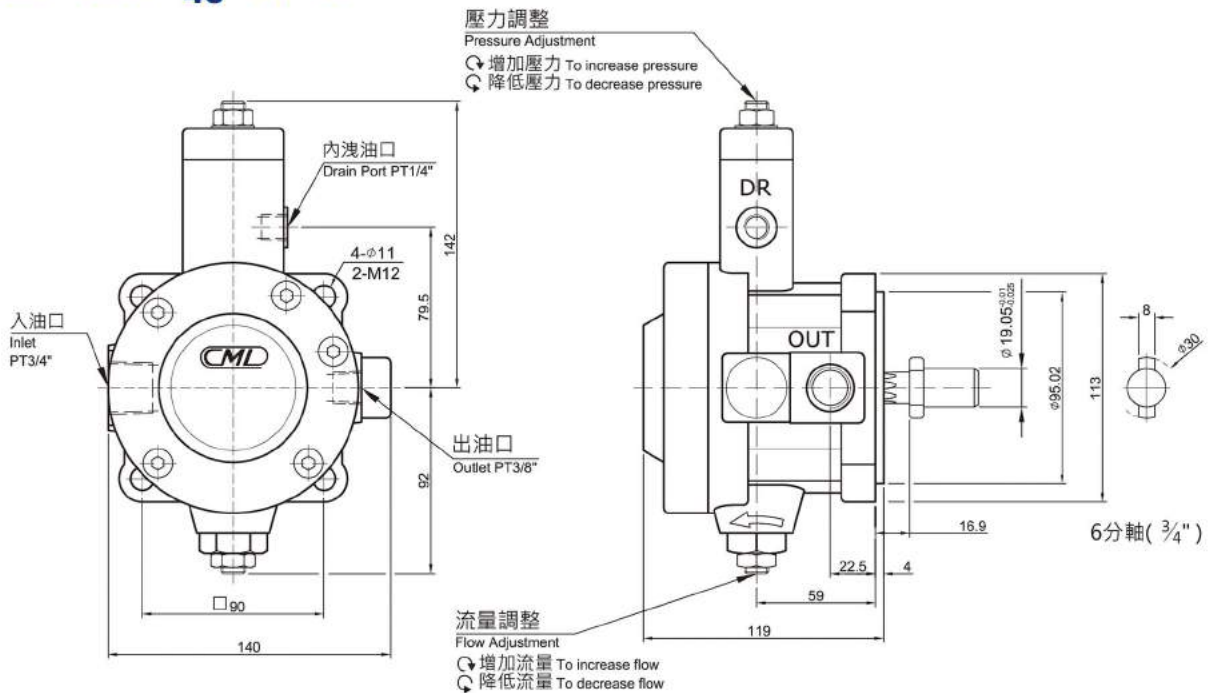

Double Variable Displacement Vane Pump

雙聯變量葉片泵

VCM-DF



油壓記號

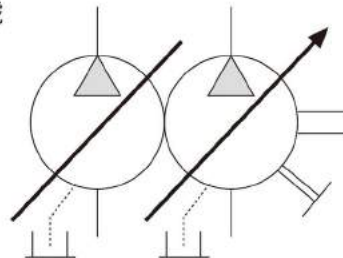

SYMBOL

型式號碼 / MODEL CODE

VCM - DF - 30 - B / 30 - B - 10

							設計號碼 Design No.
							10 : 標準 (Standard)
							後泵壓力 Secondary Pump Pressure
							SF
							A : 20 kgf/cm ²
							B : 35 kgf/cm ²
							C : 55 kgf/cm ²
							D : 70 kgf/cm ²
							後泵排量 Secondary Pump Displacement
							12L/min 20L/min 30L/min 40L/min
							前泵壓力 Shaft end Pump Pressure
							SF
							A: 20 kgf/cm ²
							B: 35 kgf/cm ²
							C: 55 kgf/cm ²
							D: 70 kgf/cm ²
							後泵排量 Shaft end Pump Displacement
							12L/min 20L/min 30L/min 40L/min
							系列號碼 Series .no.
							葉片泵系列 Vane Pump Series

◎ 外型尺寸 / MEASUREMENT

VCM - DF - 12 - ※ - ※

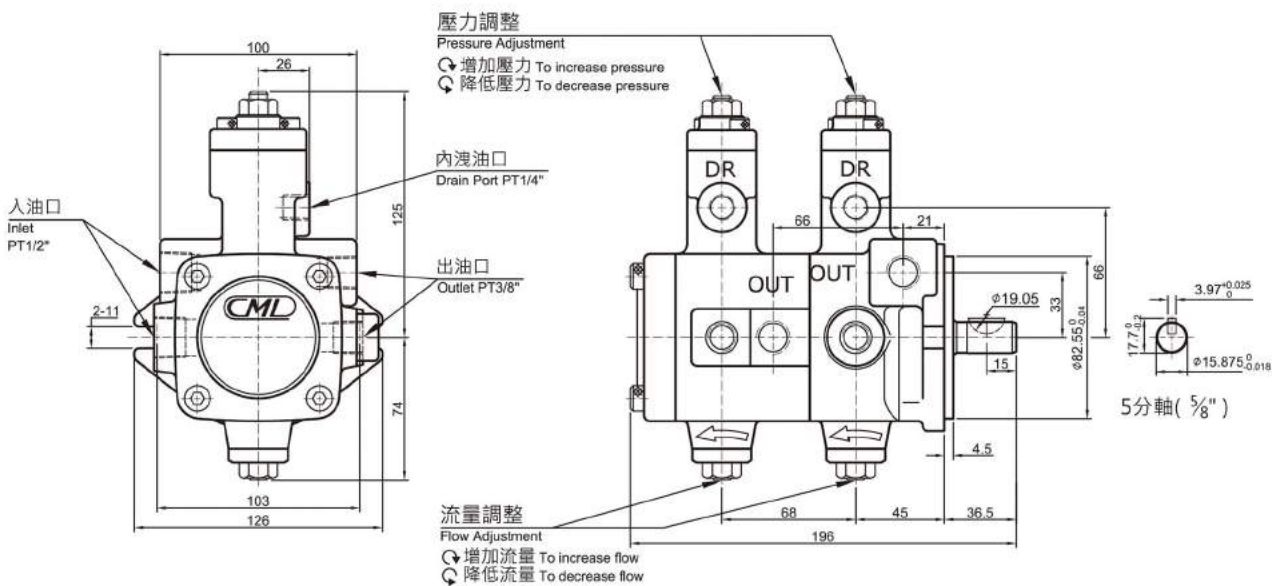

VCM - DF - 30 - ※ - ※

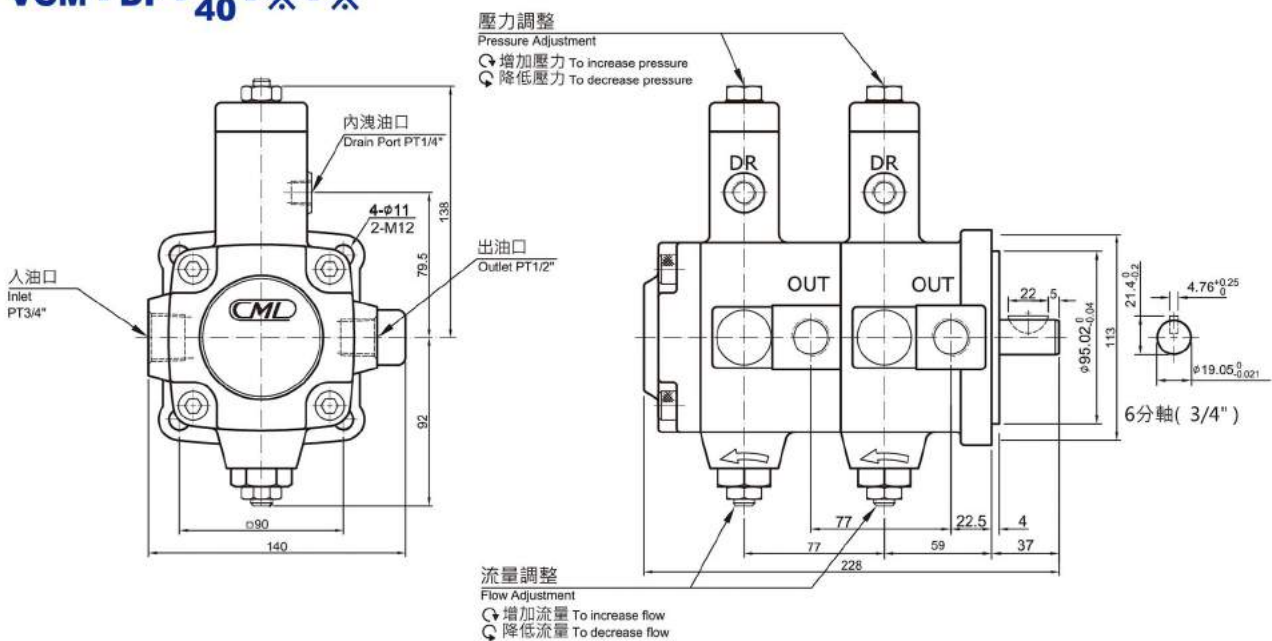

Variable Displacement Vane Pump + Gear Pump

變量葉片泵+外嚙合齒輪泵

VCM-SF/EGA



油壓記號

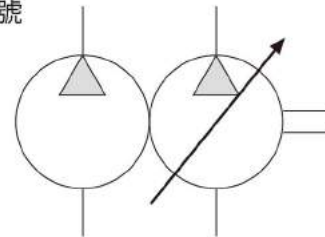

SYMBOL

型式號碼/MODEL CODE

VCM - SF - 30 - A/EGA - 4.3



產品特性/CHARACTERISTIC

1. 結合高低壓泵的特性,具備高低壓力並用的功能。
 2. 變量葉片泵省能源、低噪音平穩的特性,搭配齒輪泵 高效能的性能,是工程師在系統設計時優良的選擇。
 3. 節省體積、縮小機械空間、節省能源。
 4. 性能優異的齒輪泵可作為高壓泵或系統冷卻之用。
 5. 標準法蘭安裝及維護容易。
 6. 性能參數請參考相關之各別油泵。
1. Combinethe characteristics of both high and low pressure pumps, applicable to for high-low pressure system.
 2. Power saving, ownoise and smooth operation. Best choice for hydraulic system design for engineer.
 3. Compactness, minimize space and energy-saving.
 4. Excellent performance gear pump could be used as a high pressure source or use ascooling system.
 5. SAEstandardflange.
 6. Please refer to the table of single pump for performance figure.

技術資料 / TECHNICAL DATA

型式 MODEL	輪葉泵浦 VANE PUMP		容許回轉速 SHAFT SPEED RANGE (rpm)		重量 WEIGHT (kg)
	理論流量 THEORETICAL DISPLACEMENT (c.c./rev.)	最高壓力 MAX. PRESSURE (kgf/cm ²)	最高 MAX.	最低 MIN.	
SF-30B/EGA-*	35	1800	800		
SF-30C/EGA-*	55	1800	800		
SF-30D/EGA-*	70	1800	800		
SF-40A/EGA-*	22.2	20	1800	800	
SF-40B/EGA-*		35	1800	800	
SF-40C/EGA-*		55	1800	800	
SF-40D/EGA-*		70	1800	800	

外型尺寸 / MEASUREMENT

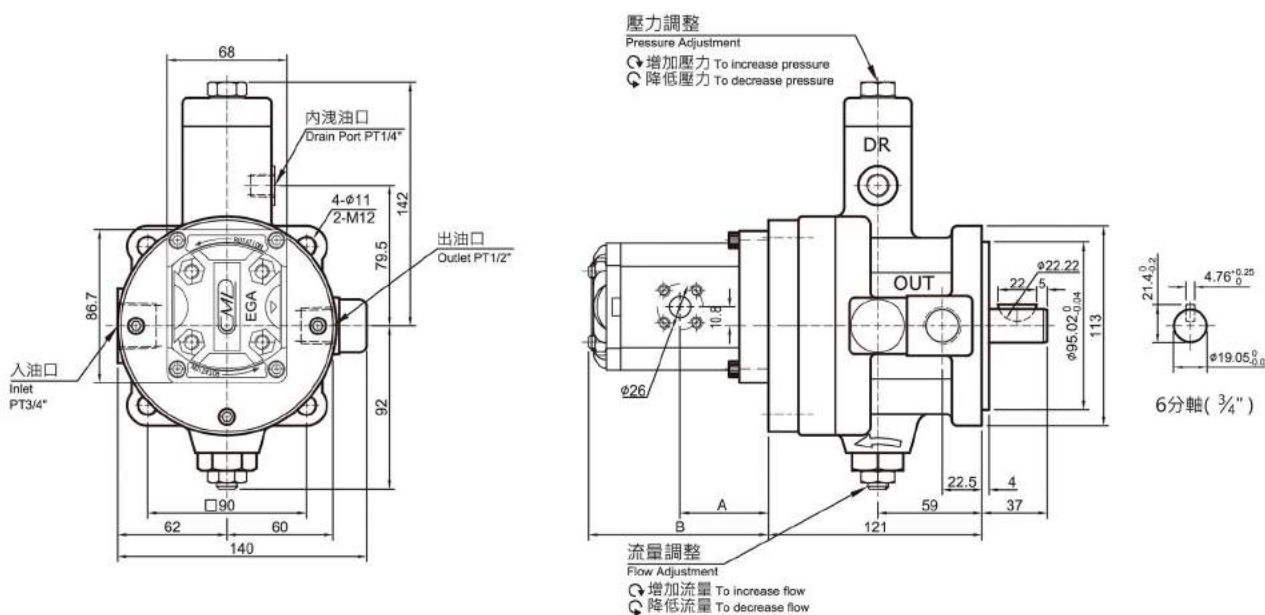

齒輪泵浦 EGA SERIES		1.2 c.c.	1.7 c.c.	2.2 c.c.	2.6 c.c.	3.2 c.c.	3.8 c.c.	4.3 c.c.	6.2 c.c.	7.8 c.c.	
最高壓力 MAX.PRESSURE		190 kgf/cm ²								175 kgf/cm ²	
尺寸 DIMENSION (mm)	A	37.8	38.5	39.5	40.5	41.5	42.5	43.5	47	50	
	B	75.5	77	79	81	83	85	87	94	100	
出入口尺寸 IN/OUT DIMENSION	INLET 入油口	10	10	10	10	12	12	12	12	12	
	OUTLET 出油口	10	10	10	10	12	12	12	12	12	
重量 WEIGHT (kg)		1.0	1.0	1.0	1.1	1.1	1.2	1.2	1.3	1.4	

Minimization Hydraulic Power Unit

小型化油壓單元



型式號碼/MODEL CODE

SPU - 25L - 2 - SF30C + 4CG - 38

電壓 Voltage

22 : 220V
38 : 380V
50/60HZ 均通用 Could Be Switched

冷卻循環泵排量 Cooling circulation pump type

4CG 6CG

壓力範圍 Pressure Range

AS : 10kgf/cm²
A : 20 kgf/cm²
B : 35 kgf/cm²
C : 55 kgf/cm²
D : 70 kgf/cm²

泵排量 Displacement at 1800rpm

12L/min
20L/min
30L/min
40L/min

馬達功率 Motor Power

1 : 0.75KW
2 : 1.5KW
3 : 2.2 KW
5 : 3.7 KW

油箱容量 Tank Capacity

10L、15L、25L、30L

小型化油壓單元 Minimization Hydraulic Power Unit

產品特性/CHARACTERISTIC

1. 搭配獨家循環泵，降低液壓油溫，增加加工精度。
 2. 油溫可控制在室溫 +15 °C 以內。
 3. 減少噪音，安裝簡便。
 4. 最小油量只需10L，減少機台內安裝空間。
 5. 動力油壓單元小型化，降低液壓油使用量。
1. Unique Cooling-Circulation pump can reduce oil temperature and maintain the machining accuracy.
 2. Oil temperature is able to be controlled +15°C with ambient environment.
 3. Noise reduced, Assembly easily
 4. Min. oil capacity is 10 Liter, save space in the machines.
 5. Compact power unit, hydraulic oil-saving 20-30%

◎ 傳統葉片泵與附冷卻葉片泵油溫性能比較圖 /

Oil temperature cooperation in between VCM-SF and VCM-SF/CG

- ▶ 與傳統變量葉片泵油溫相比，油溫較低於 7~10度(依環境溫度、操作、加工件、使用冷卻器規格等不同有所差異)。提供機台更穩定的油溫，使加工零件時能更穩定、更順暢、更精準控制。
- ▶ 測試條件：CNC車床進行實際零件加工，加工時間為八小時。

- ▶ Oil temperature of CG circulation pump will be reduced by 7-10°C (Depends on ambient temperature, operation conditions, machining materials, air-coolers, etc)
- ▶ Testing conditions: Real operation on CNC Lathe for 8 hours machining.

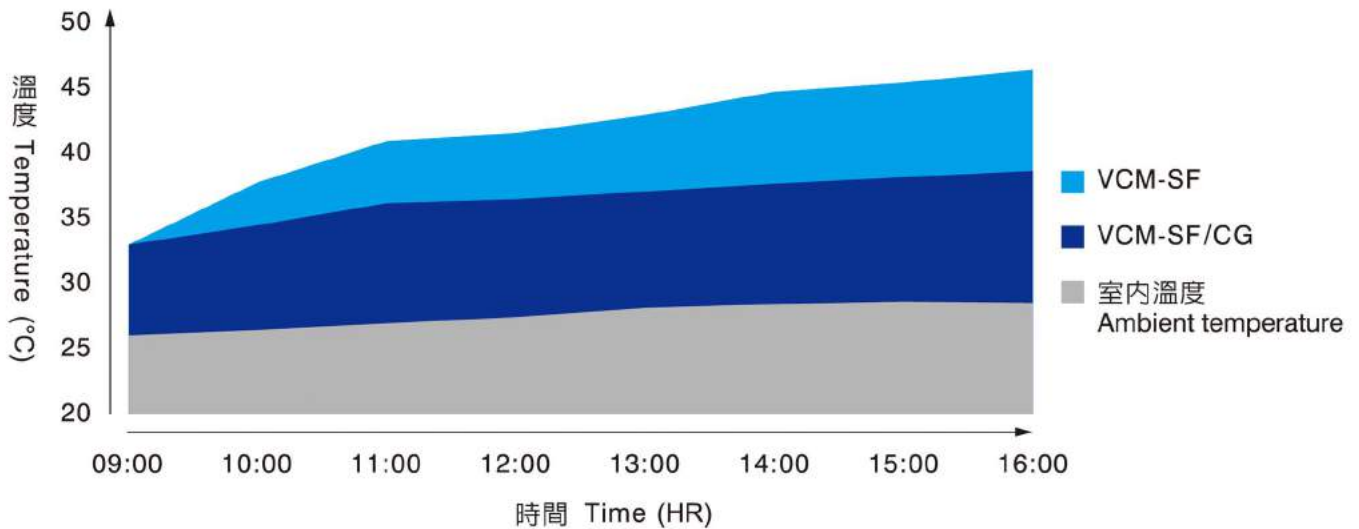

◎ 外型尺寸 / MEASUREMENT

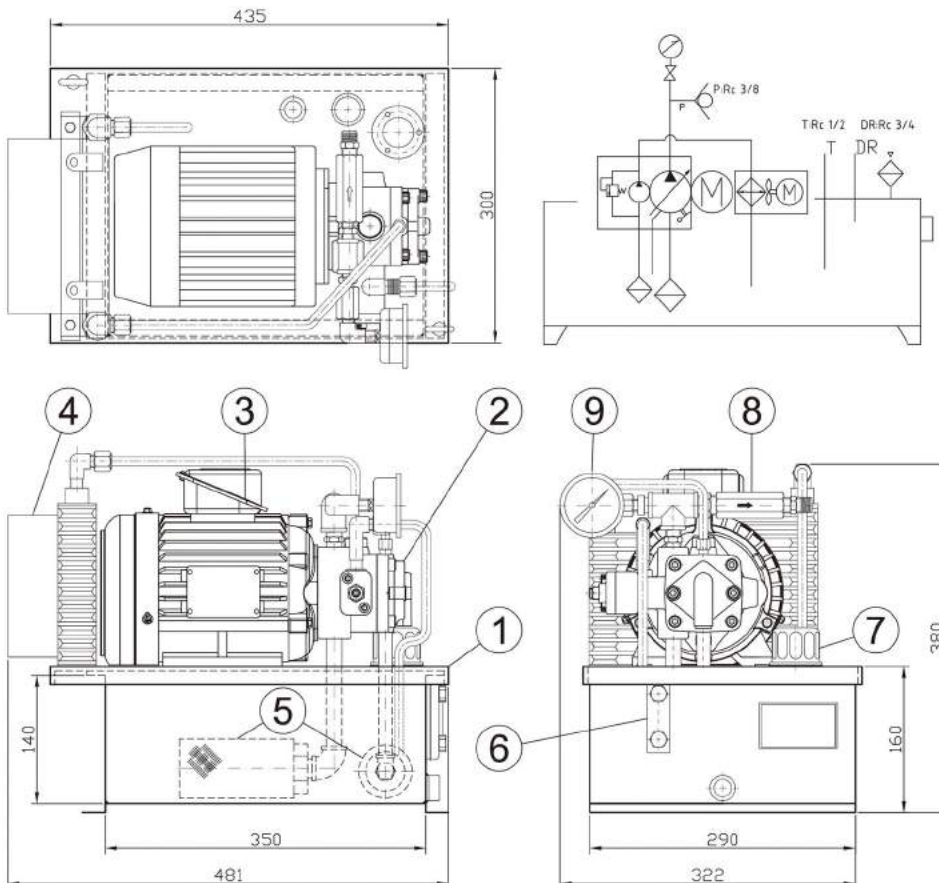

NO.	名稱 Model
1	油箱 Tank
2	循環泵浦 PUMP
3	馬達 Motor
4	油壓冷卻器 Heat Exchanger
5	濾油網 Filter
6	油面計 Oil level
7	注油器 Filler Breather
8	配管式止迴閥 Check Valve
9	壓力計 Pressure Gauge

若有不同規格、尺寸需求，請與本公司接洽。
Different dimension requirements please contact with CAMEL company.

Energy Saving Hydraulic Power Unit

節能變頻油壓單元



型式號碼 / MODEL CODE

HPU - 25L - 2 - SF30C + 4CG - 38

電壓 Voltage

22 : 220V
38 : 380V

冷卻循環泵排量 Cooling circulation pump type

4CG、6CG

壓力範圍 Pressure Range

B : 35 kgf/cm²
C : 55 kgf/cm²
D : 70 kgf/cm²

泵排量 Displacement

30 : 30L/min
40 : 40L/min

馬達功率 Motor Power

2 : 1.5KW
3 : 2.2 KW
5 : 3.7 KW

油箱容量 Tank Capacity

25L、35L

變頻節能油壓單元 Energy Saving Hydraulic Power Unit

產品特性 / CHARACTERISTIC

1. 省電幅度達50-60%(持續保壓下)。
 2. 內藏式變頻器，節省安裝空間。
 3. 動力油壓單元小型化，降低液壓油使用量。
 4. 保壓時，可有效降低動力單元噪音，提高工作舒適性。
 5. 降低液壓油溫度，提高機械加工精度，延長零件使用壽命。
 6. 操作簡易，接通電源即可啟動動力單元
 7. 節能和傳統模式選擇，可簡易切換雙模式，不影響生產線運作
1. Power consumption saving 50-60% @ Holding Pressure
 2. Inverter can be assembled inside the tank, saving space in the machines.
 3. Compact power unit, hydraulic oil can be saved.
 4. Reducing noise during Holding Pressure, offering a comfortable working environment.
 5. Reducing oil temperature, improving accuracy of machining, extending working life time of hydraulic oil and components.
 6. Easy operation, start with normal plug.
 7. Exchable from Energy-saving to traditional mode during operation.

實機變頻節能曲線圖 / Energy Saving Graph

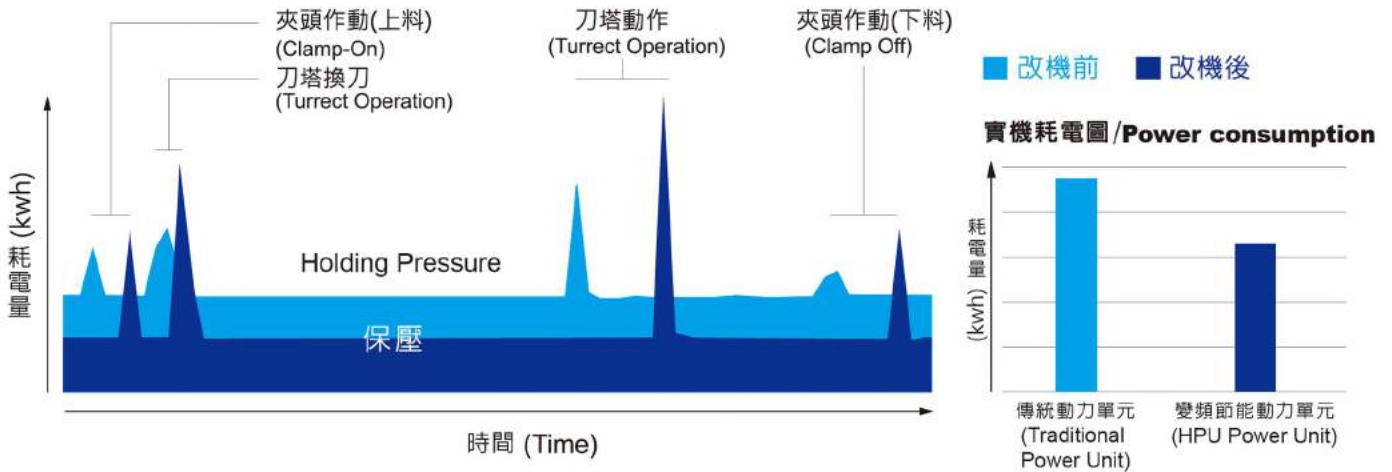

節能構造說明

- ▶ 省電30~60% (依加工工件、加工時間不同而有所差異)，保壓時間越久，效果更加明顯。
- ▶ 測試條件：台中精機小型車床實際加工一小時。其動作有換刀、夾持等動作，每工件加工時間約為115秒。一天工作16小時，連續365天工作，預計可以省下約800度電。
- ▶ Energy saved 30-60%. Depends on machining materials and time. The longer holding time, the more energy saved.
- ▶ Testing condition: Operation on Victor-Taichung CNC Lathe for 1 hour. Including turret switches, chucking, etc. Each working cycle 115s. If working time 16hr/day, 365days/year, total energy-saved 800(kWh) annually.

外型尺寸 / MEASUREMENT

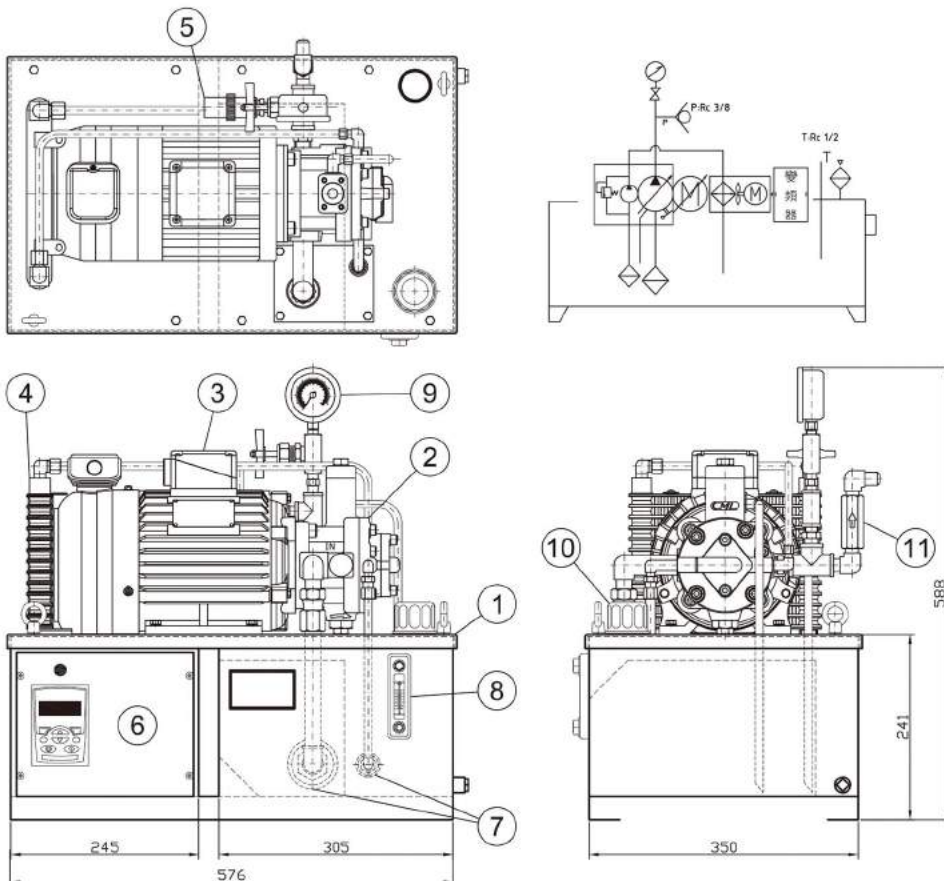

NO.	名稱 Model
1	油箱 Tank
2	循環泵浦 PUMP
3	馬達 Motor
4	油壓冷卻器 Heat Exchanger
5	壓力感測器 Pressure Transmitter
6	變頻器 Inverter
7	濾油網 Filter
8	油面計 Oil level
9	注油器 Filler Breather
10	配管式止迴閥 Check Valve
11	壓力計 Pressure Gauge

若有不同規格、尺寸需求，請與本公司接洽。
Different dimension requirements please contact with CAMEL company.

Notice

使用及注意事項

一、轉動方向

- ▶ 標準油泵的回轉方向乃以從軸心方向時正視為順時針方向。

二、液壓油

- ▶ 70kgf/cm²以下，40°C時，黏度為30-50cSt (ISO VG 32)的液壓油。
- ▶ 70kgf/cm²以上，40°C時，黏度為50-70cSt (ISO VG 46)的液壓油。

三、洩油管

- ▶ 洩油管請務必連接到油箱液面下，背壓請保持在0.3kgf/cm²以下。
- ▶ 回油管請插入油箱液面下，並盡量遠離吸油口管，或以隔板隔離。

四、工作油溫

- ▶ 連續運轉溫度約為15-60°C

五、軸心配差

- ▶ 油泵與馬達軸心偏心誤差須在0.05mm以下，角度誤差1°，在泵軸上不能有徑向力。
- ▶ 當軸心不一致時，會產生異音、震動、溫升，造成油泵故障原因。

六、流量調整

- ▶ 調整流量時須先放鬆螺帽，再旋轉調整螺絲，右轉時為減量，反之則為增量，調整完畢請務必鎖緊螺帽。

七、壓力調整

- ▶ 右轉壓力調整螺絲則輸出壓力升高，左轉則降低。

八、濾油器

- ▶ 液壓油的汙染，是油泵故障以及壽命降低的原因，請充分注意液壓油的汙染，控制污染度在NAS9級以內。

九、初次使用

- ▶ 請在無負載狀況下先行反覆啓動馬達，以排除管路及油泵中的空氣，為確保油泵系統當中所含空氣已排除，請讓油泵在無負載狀況下運轉10分鐘。

1. Direction of rotation

- ▶ The rotation of VCM-SF pump is clockwise when viewed from the shaft end.

2. Hydraulic oil

- ▶ Under 70 kgf/cm² the viscosity of oil must be within 30-50 cst at the temperature of 40°C.
- ▶ Over 70 kgf/cm² the viscosity of oil must be within 50-70 cst at the temperature of 40°C.

3. Drain piping

- ▶ The drain pipe is directly connected to the oil tank and the position must be below the level of oil.
- ▶ Let the oil return piping under the oil level of the tank , keep away from suction piping or make the divided plate.

4. Working oil temperature

- ▶ Continuous operating temperature is about 15-60°C.

5. Alignment and infollotion of pumps

- ▶ For proper alignment of pump and electric motor shaft, the eccentricity between them must be kept within 0.05mm and the eccentric angle error between them must be kept within 1°
- ▶ If centering between the driving shaft and pump shaft is incorrect, the bearing and oil seal may be domoged and noise and vibration moy occur, which cause trouble with the pump.

6. Flow adjusting

- ▶ Flow adjusting screw is turned clockwise to increase flow and counterclockwise to decrease flow.

7. Pressure adjusting

- ▶ Pressure adjusting screw is turned clockwise to increase pressure and Counterclockwise to decrease pressure.

8. Filter

- ▶ When first time operation, the pump should be at no-load state-on delivery side and be repeated on and off the electric motor a number of times to make sure the air have been bled out of the system.

9. Coughtions for starting

- ▶ Do not operate the pump of full speed right away, Instead, turn the motor input switch on-off several times so as to extract dir from the piping, then operate it continuously, At the stort, be sure to reduce the pressure of operate it unloaded.



全懋精機股份有限公司
CAMEL PRECISION CO., LTD

總公司：台中市西區玉門路64號

HEADQUATER: No. 64, Yu-Men Road, 407, Taichung, Taiwan

TEL : +886-4-24615707 FAX :+886-4-24618842

工廠：彰化縣田中鎮中州路二段455號

FACTORY: No. 455, Sec. 2, Chung-Zow Road, Tenchung, Chang-Hwa, Taiwan

E-mail: sales@camel555.com.tw <http://www.camel555.com.tw>