



WHITE PAPER

WP-2011: The Basics Of How An Encoder Works

Before you can fully understand how an encoder works, you should first understand what an encoder is and what it does. An encoder is a sensing device that provides feedback from the physical world-- it converts motion to an electrical signal which can be read by some type of control device, such as a counter or PLC. The control device can then use that signal to control a conditional event, such as activating a print head to create a mark at a specific location.

Types of Encoders

Encoders use different types of technologies to create a signal. Some common encoder technologies are mechanical, magnetic, resistive and optical. Currently, the most common technology employed by encoders is optical. Encoders may produce either incremental or absolute signals.

Incremental signals provide a series of high and low waves which indicate movement from one position to the next; there is no special indication provided by the encoder to show the specific position, only an indication that the position has changed.

Absolute encoders, on the other hand, use a unique “word” for each position, meaning that an absolute encoder provides both the indication that the position has changed and an indication of the absolute position of the encoder.

Each encoder type has its advantages, but this paper will be limited to the most common type of encoder used today: optical incremental encoders.

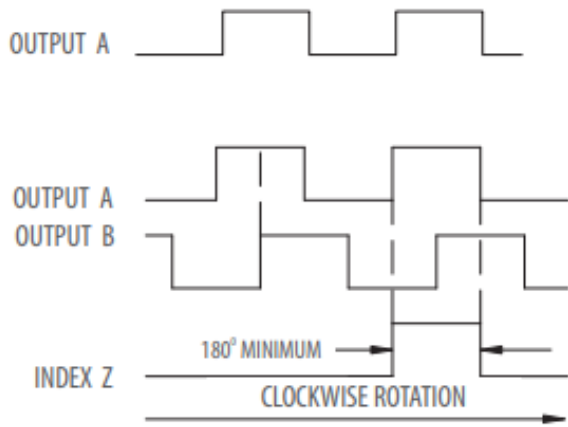

NOTE: All degrees references are electrical degree. Push-pull output does not include complimentary channels.

Output Types

Incremental encoders are available in two basic output types, single channel and quadrature.

A **single channel encoder**, often called a tachometer, is normally used in systems that rotate in only one direction and require simple position and velocity information.

Quadrature encoders have dual channels (A and B), phased 90 electrical degrees apart. These two output signals determine the direction or rotation by detecting the leading or lagging signal in their phase relationship. Quadrature encoders provide very high speed bi-directional information for very complex motion control applications.

How a Square Wave Is Produced

Figure 1, at right, outlines the basic construction of an incremental encoder. A beam of light emitted from an LED passes through a transparent disk patterned with opaque lines. The light beam is picked up by a photodiode array, also known as a photosensor. The photosensor responds to the light beam, producing a sinusoidal wave form, which is transformed into a square wave or pulse train. This pulse signal is then sent to the counter or controller which will then send the signal to produce the desired function.

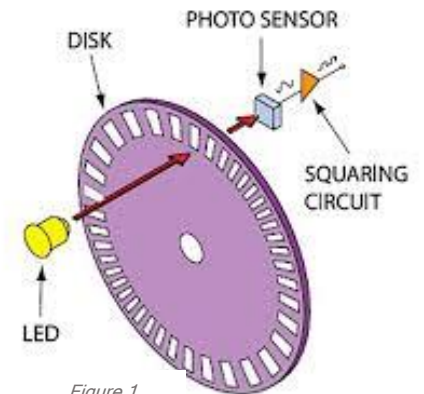

Figure 1.

Figure 1. diagram is for a typical rotary encoder. Incremental encoders can provide a once-per-revolution pulse (often called the index, marker, or reference) that occurs at the same mechanical point of the encoder shaft revolution. This pulse is on a separate output channel (Z) from the signal channel or quadrature outputs. The index pulse is often used to position motion control applications to a known mechanical reference.

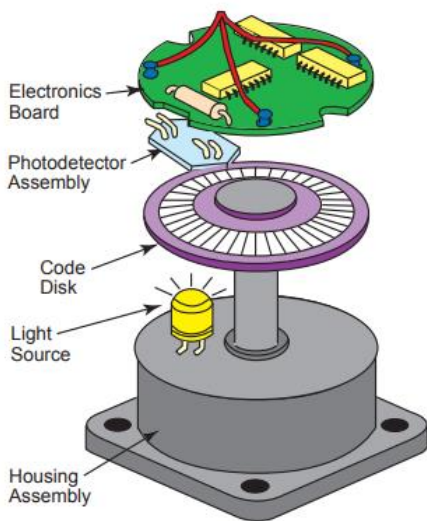

Figure 2.

Resolution

Resolution is a term used to describe the Pulses Per Revolution (PPR) for incremental encoders. Each incremental encoder has a defined number of cycles that are generated for each 360 degree revolution of the shaft. These cycles are monitored by a counter or motion controller and converted to counts for position or velocity control. Figure 2., at left, shows how the whole encoder comes together.

Application Example

Figure 3, below, shows one example of how an encoder is used in a typical motion control application. Cut-to-length, plotters, packaging and conveying, automation and sorting, filling, imaging, and robotics are all examples of applications that would use an encoder. The process is the same: a count is generated by the encoder and sent to the controller, which then sends a signal to the machine to perform a function.

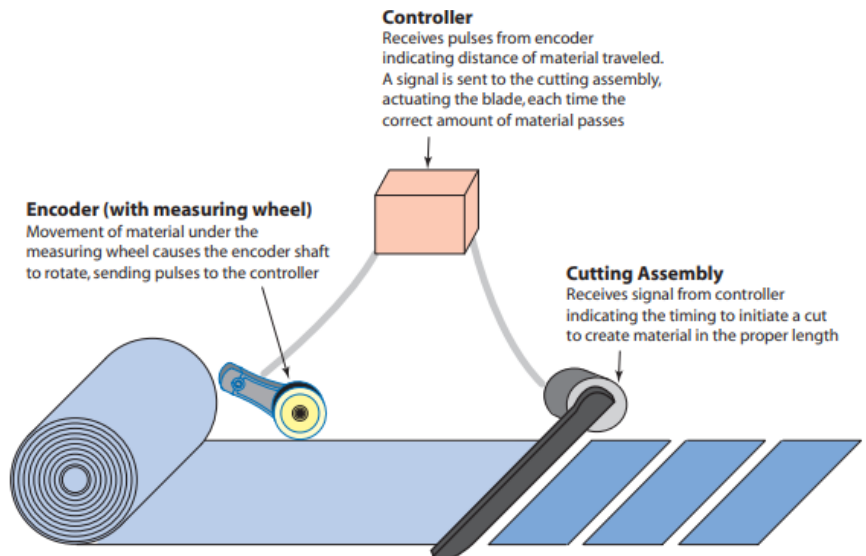

Figure 3.

For more information about how an encoder works, watch this Encoder 101 video, [“What’s an Encoder?”](#)

And if you still have questions about how an encoder would work in your specific application, or anything else encoder-related, give us a call. When you contact [BEPC](#), you talk to real engineers and encoder experts who can answer your toughest encoder questions.