

# Model 725 Heavy Duty (Formerly 730 & 735 Series)



## Features

- Standard Size 25 Package (63.5 x 63.5)
- Up to 30,000 PPR
- Standard and Industrial Housings
- Servo and Flange Mounting
- IP67 Sealing Available

Model 725 Size 25 (Formerly 730 Series) optical shaft encoder is specifically designed for the challenges of an industrial environment. But don't let its tough, industrial package fool you! It still has the performance to reach resolutions up to 30,000 pulses per revolution. The Model 725 offers both flange and servo mounting options, and is available in two distinct housing styles. The rugged Standard Housing isolates the internal electronics from the shock and stress of the outer environment. The extra heavy-duty Industrial Housing (I) features a fully isolated internal encoder unit that prolongs bearing life by using an internal flexible mount to protect the encoder from severe axial and radial shaft loading. The Industrial Housing option is the recommended solution for applications subject to continuous side loads, such as applications that drive the encoder with a measuring wheel, pulley or chain & sprocket.

## Common Applications

Motion Control Feedback, Conveyors, Elevator Controls, Machine Control, Food Processing, Process Control, Robotics, Material Handling, Textile Machines

## Model 725 Ordering Guide

Blue type indicates price adder options. Not all configuration combinations may be available. Contact Customer Service for details.

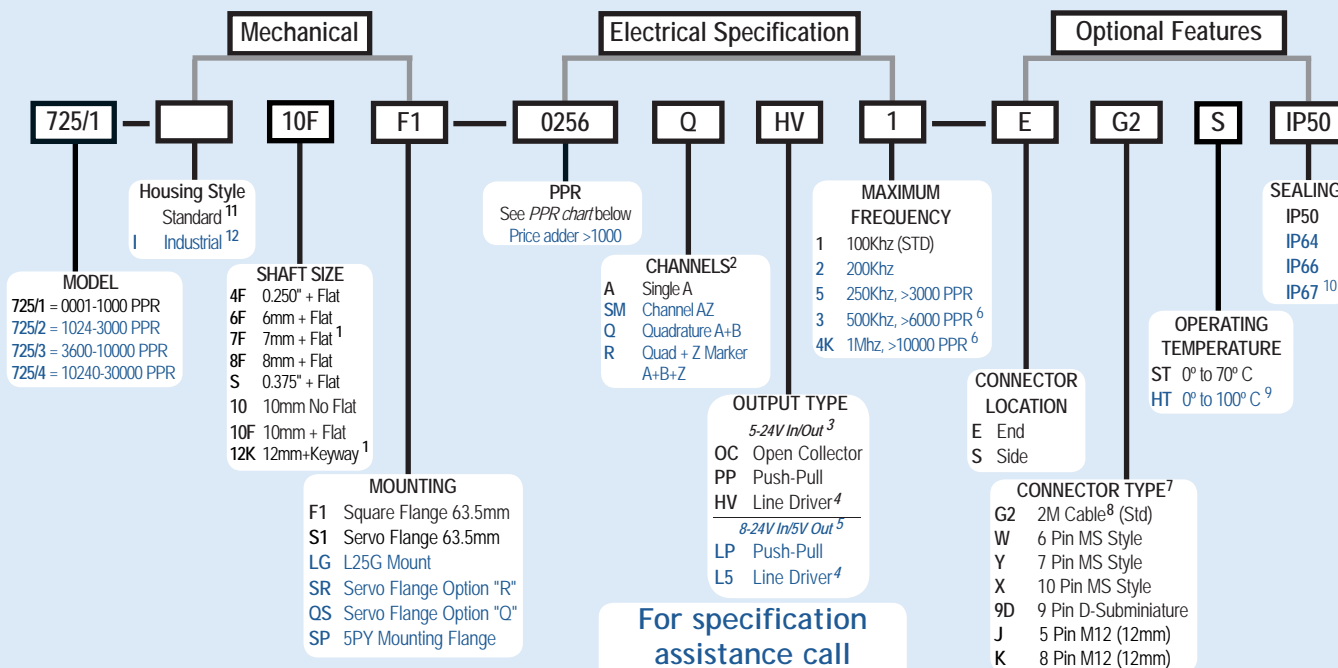

For specification assistance call  
Customer Service at  
**+44 (0)1978 262100**

## Model 725 PPR Options

0001*	0002*	0004*	0005*	0006*	0007*	0008*	0010*	0011*
0012*	0014*	0020	0021*	0024*	0025*	0028*	0030*	0032*
0033*	0034*	0035*	0038*	0040*	0042*	0045*	0050*	0060
0064*	0100	0120	0125	0128*	0144*	0150*	0160*	0192*
0200	0240*	0250	0254*	0256*	0300	0333*	0360	0400
0500	0512	0600	0625*	0635	0665*	0720	0768*	0800
0889	1000	1024	1200	1201 <sup>a</sup>	1203 <sup>a</sup>	1204 <sup>a</sup>	1250 <sup>a</sup>	1270 <sup>a</sup>
1440	1500	1800	2000	2048	2400 <sup>a</sup>	2500	2540 <sup>a</sup>	2880 <sup>a</sup>
3000 <sup>a</sup>	3600 <sup>a</sup>	4000 <sup>a</sup>	4096 <sup>a</sup>	5000 <sup>a</sup>	6000 <sup>a</sup>	7200 <sup>a</sup>	7500 <sup>a</sup>	9000 <sup>a</sup>
10,000 <sup>a</sup>	10,240 <sup>a</sup>	12,000 <sup>a</sup>	12,500 <sup>a</sup>	14,400 <sup>a</sup>	15,000 <sup>a</sup>	18,000 <sup>a</sup>	20,000 <sup>a</sup>	20,480 <sup>a</sup>
25,000 <sup>a</sup>	30,000 <sup>a</sup>							

\* Contact Customer Service for High Temperature Option.

<sup>a</sup> High Temperature Option (HT) limited to 85° C maximum for these PPR options.

New PPR values are periodically added to those listed. Contact Customer Service to determine all currently available PPR values. Special disk resolutions are available upon request.

A one-time NRE fee may apply.

## NOTES:

- 1 7mm and 12mm only available on IP50 and IP64 rated units, Not available on Industrial Housing and LG, SR, QS, SP Mountings.
- 2 Contact customer service for non-standard marker gating and phase relationship options.
- 3 24Vcc Max for High Temperature Option.
- 4 Marker Not available with 5-Pin, 6-Pin (HV-Q) or 7-Pin MS Connectors and HV option.
- 5 Standard Temperature, 60-3000 PPR Only.
- 6 Standard Cable Length Only.
- 7 For Mating Connectors, Cables - please see the Accessories Pages.
- 8 For non-standard cable lengths please contact the sales office.
- 9 0° to 85°C for certain PPR resolutions - See PPR options.
- 10 IP67 Only Available on Industrial Housing.
- 11 Leave blank for standard option.
- 12 The M4 holes on the S1 option are not available for Industrial Version - The holes are 6 x 10-23 @ 60° apart on a 47.62 PCD. The Spigot length on the S1 and F1 Industrial Options is also shorter at 4.06mm not 7.62 as in the standard version.

# Model 725 Heavy Duty (Formerly 730 & 735 Series)



## Model 725 Specifications

### Electrical

Input Voltage.....	4.75 to 24 Vcc max for temperatures up to 70° C
	4.75 to 24 Vcc for temperatures between 70° C to 100° C
Input Current.....	100 mA max with no output load
Input Ripple.....	100 mV peak-to-peak at 0 to 100 kHz
Output Format.....	Incremental- Two square waves in quadrature with channel A leading B for clockwise shaft rotation, as viewed from the encoder mounting face. See <i>Waveform Diagrams</i> below.
Output Types.....	Open Collector- 100 mA max per channel Pull-Up- 100 mA max per channel Push-Pull- 20 mA max per channel Line Driver- 20 mA max per channel (Meets RS 422 at 5 Vcc supply)
Index.....	Occurs once per revolution. The index for units >3000 PPR is 90° gated to Outputs A and B. See <i>Waveform Diagrams</i> below.
Max Frequency.....	Up to 1 MHz
Noise Immunity.....	Tested to BS EN61000-4-2; IEC801-3; BS EN61000-4-4; DDENV 50141; DDENV 50204; BS EN55022 (with European compliance option); BS EN61000-6-2; BS EN50081-2
Symmetry.....	1 to 6000 PPR: 180° (±18°) electrical at 100 kHz output 6001 to 20,480 PPR: 180° (±36°) electrical
Quad Phasing.....	1 to 6000 PPR: 90° (±22.5°) electrical at 100 kHz output 6001 to 20,480 PPR: 90° (±36°) electrical
Min Edge Sep.....	1 to 6000 CPR: 67.5° electrical at 100 kHz output 6001 to 20,480 PPR: 54° electrical >20,480 PPR: 50° electrical
Rise Time.....	Less than 1 microsecond
Accuracy.....	Instrument and Quadrature Error: For 200 to 1999 PPR, 0.017° mechanical (1.0 arc minutes) from one cycle to any other cycle. For 2000 to 3000 PPR, 0.01° mechanical (0.6 arc minutes) from one cycle to any other cycle. Interpolation error (units > 3000 PPR only) within 0.005° mechanical. (Total Optical Encoder Error = Instrument + Quadrature + Interpolation)

### Mechanical

Max Shaft Speed.....	8000 RPM. Higher shaft speeds may be achievable, contact Customer Service.
Shaft Size.....	0.375" (standard), 0.250", 6 mm, 8 mm, 10 mm and 12 mm
Shaft Material.....	303 stainless steel
Shaft Rotation.....	Bi-directional
Radial Shaft Load.....	16 Kg max (standard housing) 36 Kg max (industrial housing)
Axial Shaft Load.....	18 Kg max (standard housing) 36 Kg max (industrial housing)
Starting Torque.....	7.0615 X 10 <sup>-3</sup> Nm typical with no seal 1.412 x 10 <sup>-2</sup> Nm with IP64 shaft seal 2.118 X 10 <sup>-2</sup> Nm typical with IP66 shaft seal 4.943 X 10 <sup>-2</sup> Nm typical with IP67 shaft seal
Electrical Conn.....	6-, 7-, or 10-pin MS Style, 5- or 8-pin M12 (12 mm), 9-pin D-subminiature, or gland with 2 Metres of cable (foil and braid shield, 24 AWG conductors)
Housing.....	Black non-corrosive finish
Bearings.....	Precision ABEC ball bearings
Mounting.....	Flange, servo, or 5PY
Weight.....	566 grams typical
<b>Environmental</b>	
Operating Temp.....	0° to 70° C for standard models 0° to 100° C for high temperature option (0° to 85° C for certain resolutions, see PPR Options.) -40° to 70° C
Storage Temp.....	-25° to +85° C
Humidity.....	95% RH non-condensing
Vibration.....	725N: 10 g @ 58 to 500 Hz 725I: 20 g @ 58 to 500 Hz
Shock.....	725N: 50 g @ 11 ms duration 725I: 75 g @ 11 ms duration
Sealing.....	IP50 standard, IP64, IP66 and IP67 optional

## Model 725 Flange Mount (F1)

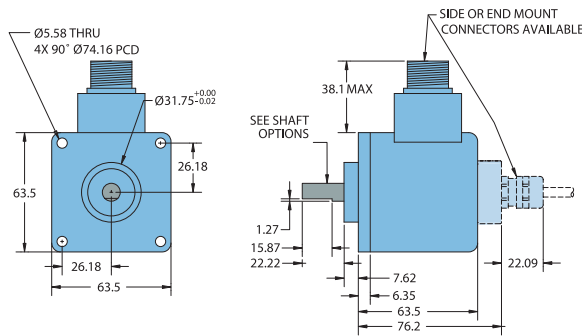

## Model 725 63.5mm Servo Mount (S1)

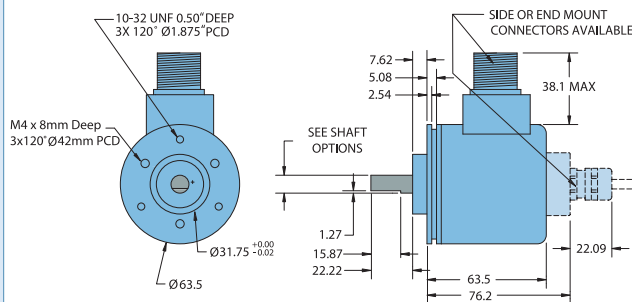

## Model 725 63.5mm Servo Mount (SR)

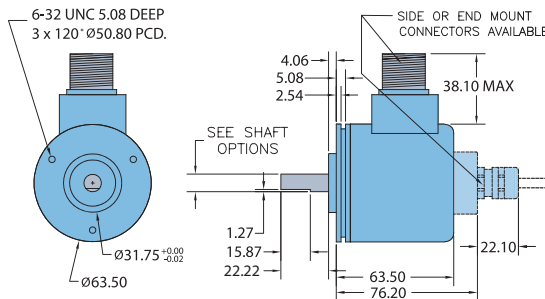

## Model 725 63.5mm Servo Mount (QS)

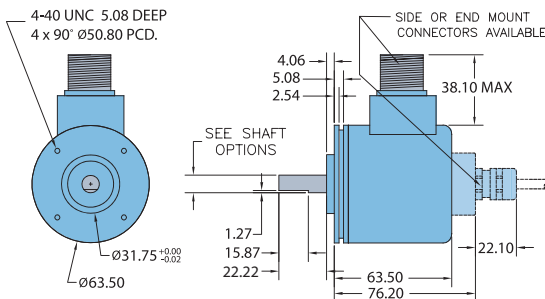

All dimensions are in mm with a tolerance of ±0.127mm or ±0.254 unless otherwise specified

Incremental Shaft Encoders

# Model 725 Heavy Duty (Formerly 730 & 735 Series)



## Model 725 66.54mm Servo Mount (LG)

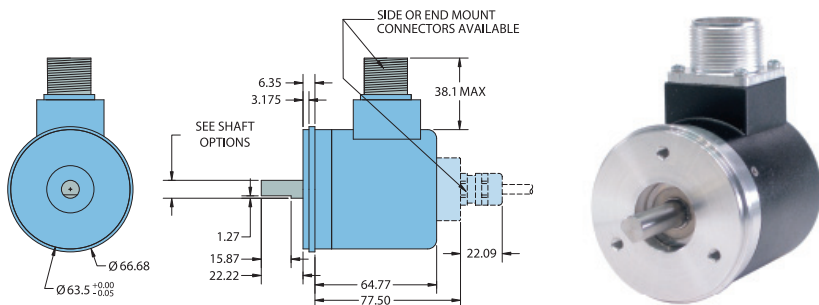

### Waveform Diagrams

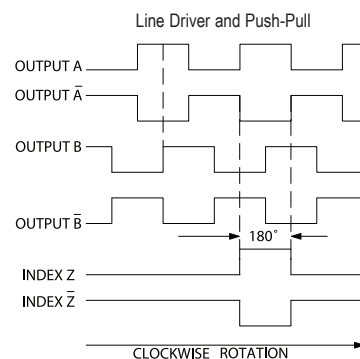

NOTE: ALL DEGREE REFERENCES ARE ELECTRICAL DEGREES  
NOTE: ALL DEGREE REFERENCES ARE ELECTRICAL DEGREES  
NOTE: PUSH-PULL OUTPUT DOES NOT INCLUDE COMPLEMENTARY CHANNELS

## Model 725 5PY Optional Mounting (SP)

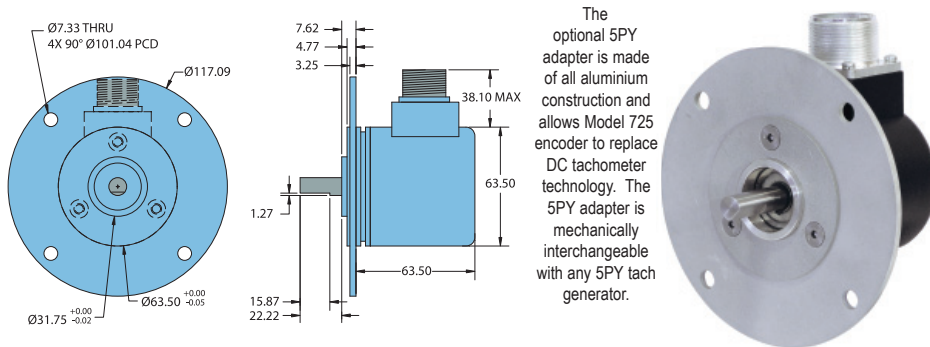

The optional 5PY adapter is made of all aluminium construction and allows Model 725 encoder to replace DC tachometer technology. The 5PY adapter is mechanically interchangeable with any 5PY tach generator.

All dimensions are in mm with a tolerance of  $\pm 0.127\text{mm}$  or  $\pm 0.254$  unless otherwise specified

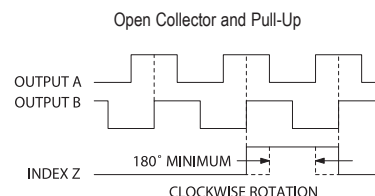

NOTE: ALL DEGREE REFERENCES ARE ELECTRICAL DEGREES  
NOTE: INDEX IS POSITIVE GOING

### Connector Pin-Outs

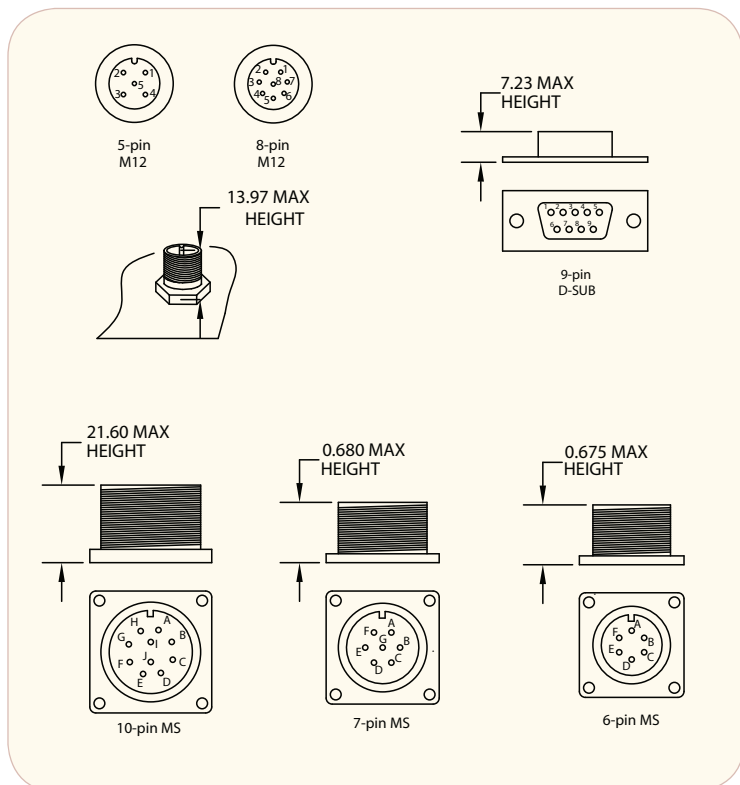

### Wiring Table

Function	Gland Cable Wire Color	5-pin M12	8-pin M12	10-pin MS	7-pin MS L5 HV-Q	7-pin MS PP OC, LP HV-R	6-pin MS PP OC, LP HV-R	6-pin MS L5 HV-Q	9-pin D-sub
Com	Black	3	7	F	F	F	F	F	9
+Vcc	White	1	2	D	D	D	D	D	1
A	Brown	4	1	A	A	A	A	A	2
A'	Yellow	—	3	H	C	—	—	C	3
B	Red	2	4	B	B	B	B	B	4
B'	Green	—	5	I	E	—	—	E	5
Z	Orange	5	6	C	—	C	C	—	6
Z'	Blue	—	8	J	—	—	—	—	7
Case	—	—	—	G	G	G	—	—	8
Shield	Screen	—	—	—	—	—	—	—	—

CAUTION - Always check wiring colour code against Encoder Label due to changes in specification since September 2006

# A Step Above The Rest



Size 25 encoders (63.50mm diameter) are among the most popular encoders in the world. As a result, nearly every encoder manufacturer in the world makes them. The problem is, not every Size 25 encoder is built to the same exacting standards of quality and reliability as the Model 725 from British Encoder Products Company and Encoder Products Company (BEPC & EPC).

So, what's the problem? If you have used other Size 25 encoders, you have probably experienced reliability problems such as sensor crashes and disc breakage. The typical construction of a Size 25 encoder (shown below) uses a single set of closely spaced shaft bearings and a large diameter (typically 50.80mm) glass disc mounted to the shaft. The glass disc is generally supported on the shaft hub by just 15% of the surface area and has a thickness of 0.7mm. In addition, these units commonly require a relatively narrow air gap (typically 0.05mm) between the disc and sensor in order to properly calibrate the signal. Because of this combination, a small amount of side loading (force from installation requirements, vibration, shock, or other conditions) can move the shaft enough for the attached disc to make contact with the sensor or some other portion of the stationary PCB. The result is damage to the disc or sensor, or even disc breakage.

Then, what's the solution? When design engineers at EPC/BEPC set out to design a better Size 25 encoder, their goal was to solve the typical problems without affecting the price of the encoder. The result - the Model 725, a Size 25 encoder. The first goal was to

make it more difficult for shaft movement from side load to cause damage. Using BEPC's advanced sensor technology, the air gap between the disc and sensor doubled from 0.05mm to 0.1mm, and the disc diameter was reduced from 50.80mm to 33.02mm. The next goal was to increase the durability of the disc itself. Disc thickness was more than doubled (from 0.7mm to 1.50mm), manufactured using EPC's proprietary process, and supported by 30% of the disc surface area. Finally, it was time to improve the resistance to side load movement altogether, so the 725 was given dual heavy-duty bearings, generously spaced to disperse the load over a larger portion of the shaft.

But EPC's innovative engineering team wasn't satisfied. They really wanted to solve the problems of a truly rough environment. What they designed was the Model 725-I - the industrial 725 housing option. An encoder that is as robust as possible within its price category. Using the improvements developed in the 725N, EPC's engineering team developed the "encoder-within-an-encoder" design. With this design, the 725-I adds two extra, heavy-duty bearings to the two contained within the internal encoder for a total of four bearings! These two extra bearing sets are separated in such a way that side load stresses become isolated between the two bearing sets and never reach the inner encoder. In addition, the internal encoder is mounted to the 725-I's housing using EPC's pioneering flex mount, further isolating the internal optics and electronics from outside forces.

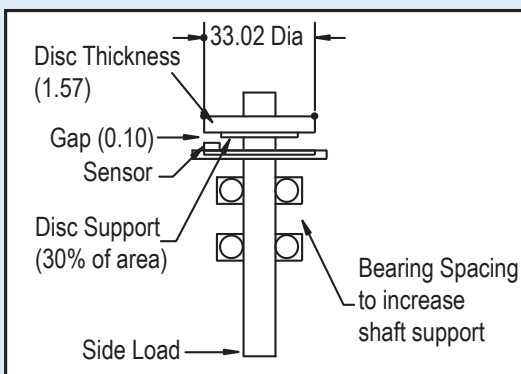

### Better - The Model 725 Standard

BEPC has designed out the common problems experienced by the average Size 25 encoder. Notice the generous air gap (double that of typical Size 25 encoders), thick code disc (more than twice the thickness), small diameter, large disk support area, and large bearing spacing - each an element which increases durability and reliability.

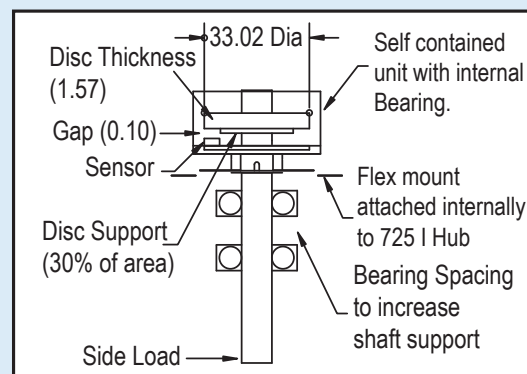

### Best - The Model 725 Industrial

The design improvements made in the Model 725 I, places them in their own internal encoder housing, and surrounds the internal unit with a second, rugged housing with a separate set of heavy duty bearings, all for an encoder that laughs at applications which eat other encoders alive!

For specification assistance call Customer Service at +44 (0)1978 262100